

Dry running vacuum pumps

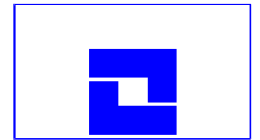

SIHI *dry* H250

GENERAL TECHNICAL DATA

Suction speed	290 m ³ /h
Final pressure	< 0,1 mbar abs
Gas outlet temperature	< 135 °C
Installed power	8 kW
Power absorption at the final pressure	5 kW
Purge gas consumption	max. 20 NI/min
Cooling water T _{min}	+ 10°C
Cooling water T _{max}	+ 35°C
Sound level as per DIN ISO 9614 / 21680	< 63 dB(A)
Weight of the vacuum system	approx. 580 kg



CONSTRUCTION TYPE

The vacuum system **SIHI *dry* H250** is based upon the dry running twin screw principle. The screw-shaped displacing bodies counter-rotate without contact. The pump inlet is at the top and the outlet at the geodetically lowest position (top-down pumping).

In contrast to conventional pumps the both screw spindles are not mechanically but electronically synchronized. This innovative drive conception is the basis for a stepwise development of the vacuum pump to an intelligent vacuum system which takes on additional functions as the valve-, and pressure control for example. Furthermore the intelligent system offers the possibility to exactly monitor the important process data in order to ensure a maximum of process safety.

DESIGN

The vacuum system **SIHI *dry* H250** has been developed for the use in areas with and without explosion hazard. The flexibility of the modular system allows its adaptation to any process according to the attached selection table.

The cooling water circuit which contains a casing shell as well as a screw cooling allows the adjustment of the surface and gas temperatures. For further optimizing the temperatures the **SIHI *dry* H250** offers the possibility of the integration of a direct gas cooling.

The drive control system protects the mechanical components as well as the motors against overload. Under extremely difficult operating conditions as e.g. backwater surge the system automatically reduces its speed so that any damages are avoided.

PROPERTIES

- No oil lubrication / sealing liquid in the working chamber
- No gearing and no transmission lubricant
- Shaft seal without contact
- Rapid disassembly of the pumping chamber without bearing dismounting
- Shock pressure proof casing (16 bar test pressure)
- Electronic drive synchronization free of wear
- Process data recording with fault diagnosis
- Low gas temperatures by inner-cooled screw – shaped displacement bodies

Characteristic

Every operating point below the characteristic curve can be achieved from Drive variant DYNAMIC upwards.

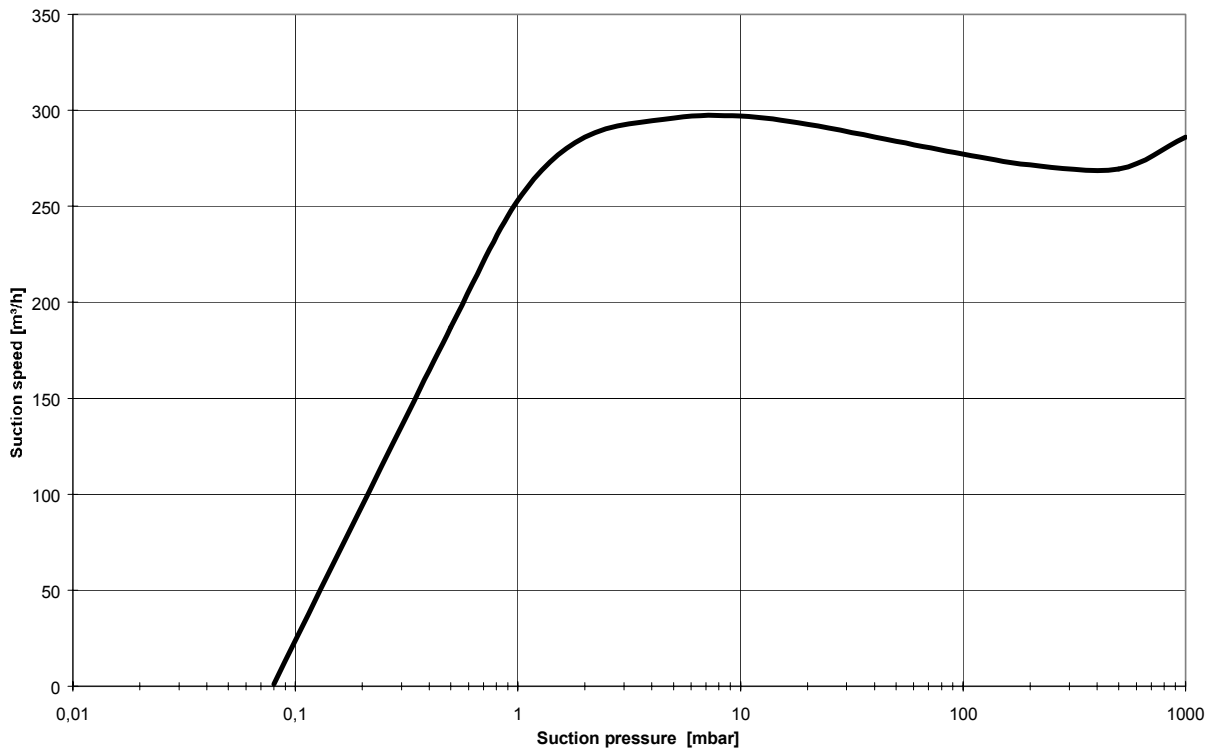

Sectional drawing

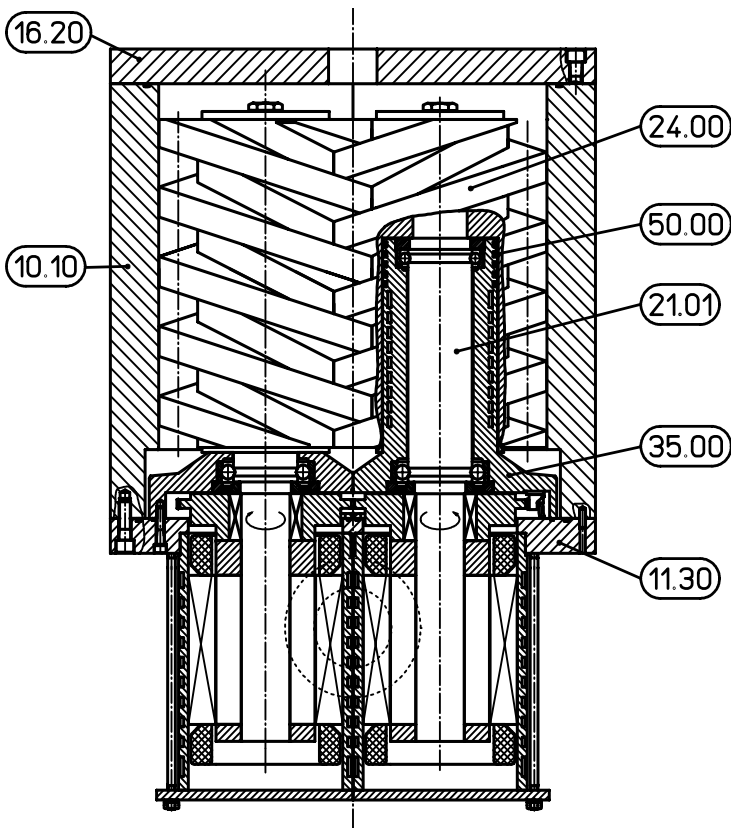

Materials

Item	Component	Material
10.10	Casing	GGG 40.3
11.30	Intermediate plate	GGG 40.3
16.20	Casing cover	1.0553
24.00	Rotor	1.4122
21.01	Shaft	1.4122
36.00	Bearing cartridge	1.4122
50.00	Purge gas throttle	GG25

COOLING MECHANISMS

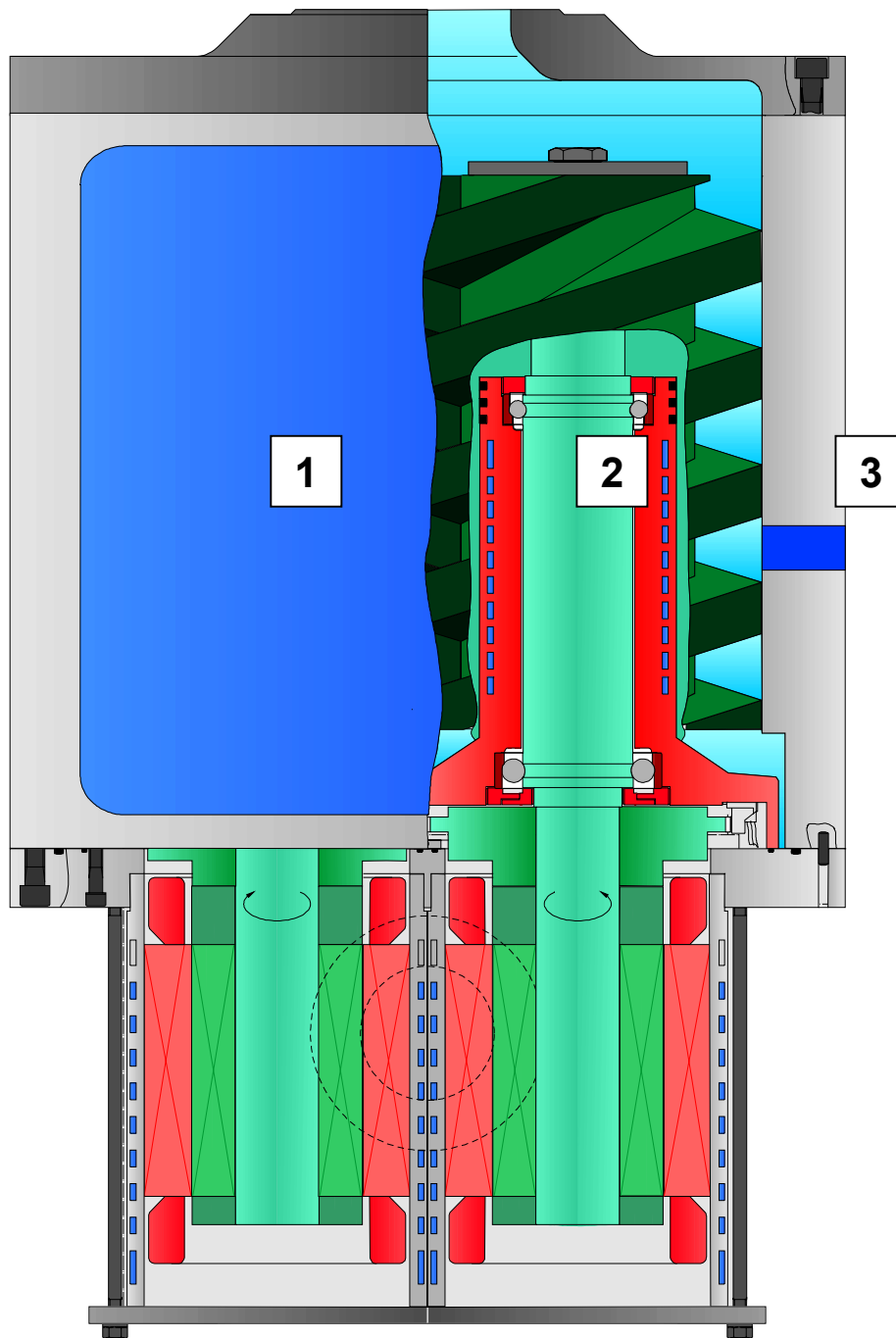

Adjusted gas temperatures for the individual process:

1

Casing – basic water cooling
Basic cooling

2

Screws - Inner cooling
Reduces the temperature gradient across the vacuum chamber, and ultimately permits lower temperatures within the pump

3

Direct gas cooling (optional)
Avoids deposits in the inner pump chamber

SCOPE OF DELIVERY

The basic design of **SIHI^{dry}** incorporates static FEP O-Ring type casing seals along with the following components:

- Drive electronics fitted in the connecting casing
- Cooling water circuit for cooling of the pump casing, drive motors, and twin-screws
- Suction strainer in order to avoid detrimental particle ingress into the pump.

VARIATION IN DRIVE CONTROL

BASIC

Includes:

- **Fixed speed**
- AC supply
- Input: start/stop
- Input: reset of failure
- Output: operation/failure
- Serial interface

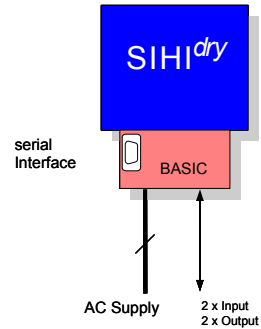

DYNAMIC

For the adaptation of the suction capacity to the actual requirement.

Includes:

- **Variable speed**
- AC supply
- Input: start/stop
- Input: reset of failure
- Analogue input: set value
- Output: operation/failure
- Serial interface

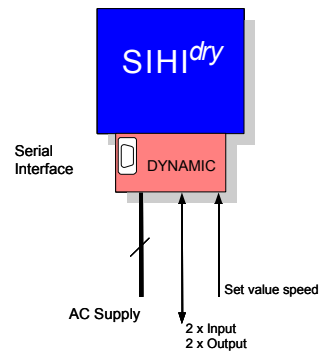

CONTROL

Fully integrated into the system, this control provides some essential process and operating features. These include: Warm up cycles; vacuum switching on/off; flushing for clean in place; N2 purging; and other external trips that can be hard wired into the system such as level and/or temperature gauges, etc. Importantly, the control does not require any further programming nor logic by the customer.

Moreover a vacuum regulation in a range from 0-100% can be realised.

Following signals are available:

- Digital status signals (vacuum operation, warning, stand-by, emergency stop, if necessary cleaning)
- Analogue signals (torque, speed, and, if necessary the suction pressure and different temperatures)
- Digital set points (start, stop, vacuum operation, and, if necessary cleaning)
- Analogue set points (pressure, speed)

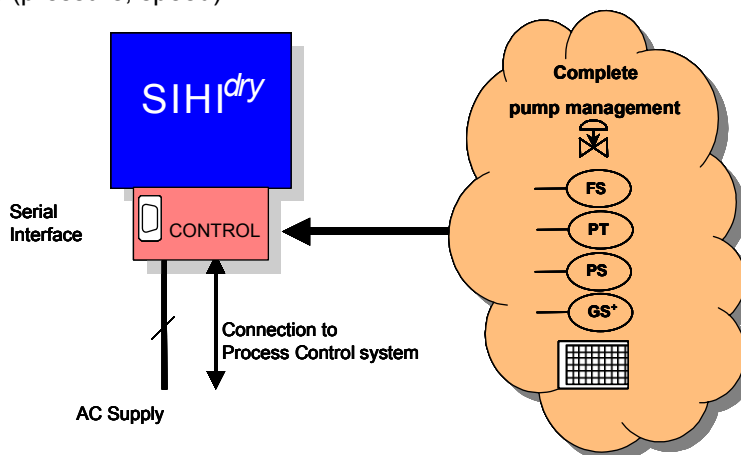

OPTIONAL ACCESSORIES

Module Purge Gas Ex

The standard EExP gas system regulates, controls, and monitors the inert N₂ pressure at the shaft seal. It permits the unit to be installed within a hazardous area according to the ATEX – directive. The system is completely integrated and parameterised.

Module Secondary Cooling Water Circuit

Complete with circulating pump, flow indicator, pressure accumulator, adjustment valves, thermostatic control valve, and heat exchanger; this extensive option is fully integrated into the base-plate. This is particularly useful in areas where site cooling water feed and return lines have very low differential pressures, and is normally very poor quality. Closed loop cooling allows the flow to be accurately regulated from full flow conditions for effective cooling, down to zero flow for effective heating.

Suction Valve Module

This module allows the pump to be isolated from the process at desired times. An example may be whilst the pump reaches pre-determined temperature, or rises above maximum temperature thresholds for selected organic (T4) media. This is carried out via a pneumatically operated suction line valve that is fully integrated within the CONTROL drive variant. Also, in standby situations, the valve avoids reverse flow through the unit whilst connected into common vacuum lines.

Outlet Valve Module

This module enables the safe shutoff of the *SIHI dry* at the suction side from the recipient by means of a pneumatically driven valve. The penetration of residual media into the pump as well as the return flow of exhaust gas through the pump into the recipient are avoided. The control of the valve is taken over by the electronics of the *SIHI dry* when the CONTROL drive variant is used.

Clean in Process Module

Perfectly suited to processes that employ polymerising, subliming, or basically sticky substances, this module allows automatic flushing from a solvent drum. Moreover, with an Angular Difference reading available from the pump, the operator can monitor the extent of any build up in order to optimise cleaning. The flushing valve can also be used for N₂ purging in order to provide an inert atmosphere within the machine after it has been stopped, and allowed to cool. This module is fully integrated into the *SIHI dry* when CONTROL drive variant is used.

Direct Gas Cooling Module

This system takes exhaust gas from the pump, passes it through a heat exchanger, and injects a small amount back into the pump. By carrying the cooling in this mode of operation, the cooled, dry gas is injected into the later stages of the twin screw thereby not detrimentally hindering the flow capacity at the suction. This option ensures that there is a flow rate even at low pressures in order to avoid deposition of thermally sensitive media.

Flame Arrester Module

Certified and tested in accordance with ATEX for use in both Zone 1 and Zone 0 process atmospheres, deflagration and detonation arresters can provide extra safety.

Temperature Measurement Module

By integrating temperature transmitters into the system, this module provides additional vacuum pump safety and recording.

Pressure Measurement Module

This module allows the measurement of different process pressures within the vacuum system. This module is fully integrated into the *SIHI dry* when drive variant CONTROL is used.

Operator Indicator Panel Module

Available when the drive variant CONTROL is requested, the panel provides the operator with a simple visual indication of the pump parameters. Characteristics like speed, pressure, torque, temperature, and the important angular difference, are available from a simple push button menu, and can be seen within the LCD.

PARA^{dry} Parameter Modification Module

Eliminating the need to employ PLC programmers, the *PARA^{dry}* software enables the principle process engineer to modify specific pump parameters. Such parameters are at the discretion of the customer and may include max/min temperature boundaries, speed and pressure, settings, warm up cycles, etc. providing long term future running adaptability, a standard windows based computer is needed.

FLOW DIAGRAM

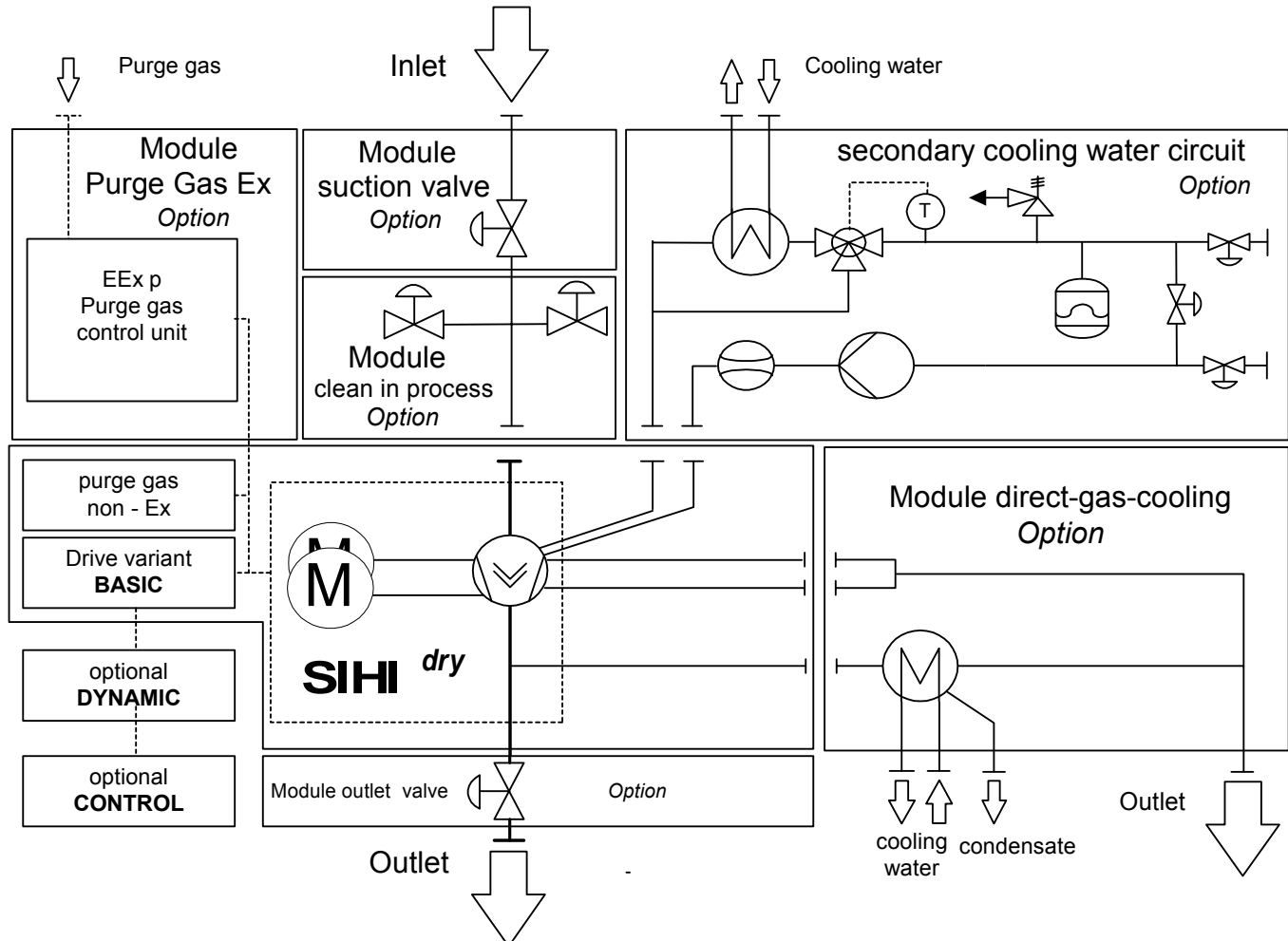

DIMENSION TABLE

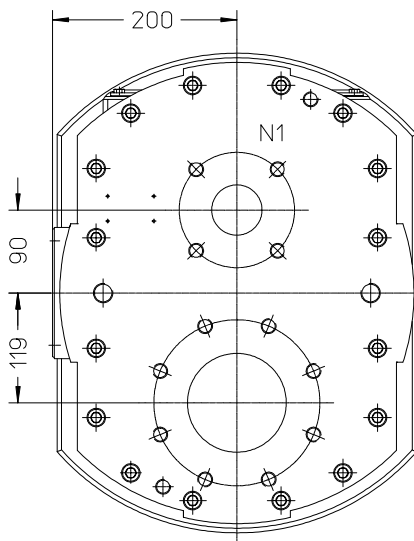
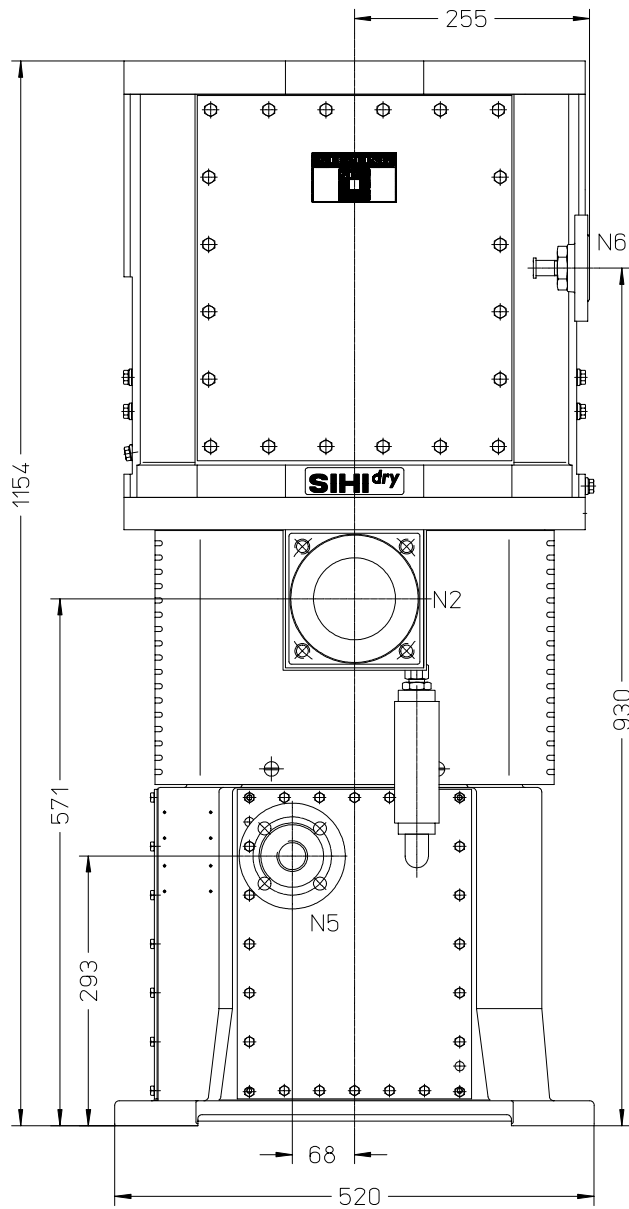
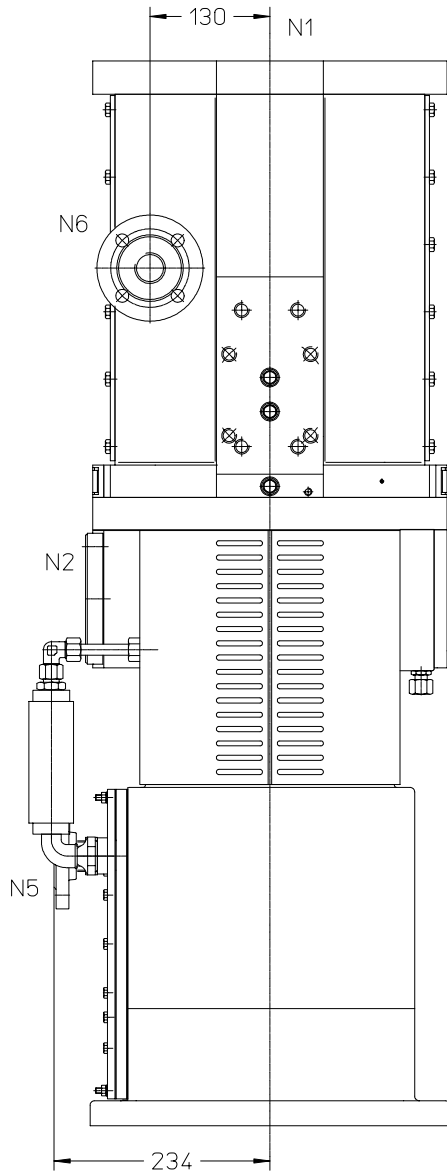

	designation	DN	PN	bolting
N1	inlet	50	16	4 × M16
N2	outlet	80	16	4 × M16
N5	cooling liquid inlet	25	16	4 × ø14
N6	cooling liquid outlet	25	16	4 × ø14

Sterling SIH GmbH

Lindenstraße 170, 25524 Itzehoe, Germany, Telefon +49 (0)48 21 / 7 71 - 01, Telefax +49 (0)48 21 / 7 71 - 274