

Dry running vacuum pumps



SIHI^{dry} M100

GENERAL TECHNICAL DATA

Suction capacity	100 m ³ /h
Final pressure	< 0,7 mbar abs
Gas outlet temperature	< 135 °C
Power absorption at the final pressure	2,5 kW
Purge gas consumption	max. 20 NI/min
Cooling water T _{min}	+ 10°C
Cooling water T _{max}	+ 35°C
Sound level as per	< 54 dB(A)
DIN ISI 9614 / 21680	
Weight of the vacuum system	approx. 260 kg



SIHI^{dry}M100

CONSTRUCTION TYPE

The vacuum system **SIHI^{dry}M100** is based upon the dry running twin screw principle. The screw-shaped displacing bodies counter-rotate without contact. The pump inlet is at the top and the outlet at the geodetically lowest position (top-down pumping).

In contrast to conventional pumps the both screw spindles are not mechanically but electronically synchronized. This innovative drive conception is the basis for a stepwise development of the vacuum pump to an intelligent vacuum system which takes on additional functions as the valve-, and pressure control for example. Furthermore the intelligent system offers the possibility to exactly monitor the important process data in order to ensure a maximum of process safety.

DESIGN

The vacuum system **SIHI^{dry}M100** has been developed for the use in areas with and without explosion hazard. The flexibility of the modular system allows its adaptation to any process according to the attached selection table.

The cooling water circuit which contains a casing shell allows the adjustment of the surface and gas temperatures. The drive control system protects the mechanical components as well as the motors against overload. Under extremely difficult operating conditions as e.g. backwater surge the system automatically reduces its speed so that any damages are avoided.

PROPERTIES

- No oil lubrication / sealing liquid in the working chamber
- No gearing and no transmission lubricant
- Shaft seal without contact
- Rapid disassembly of the pumping chamber without bearing dismounting
- Shock pressure proof casing (16 bar test pressure)
- Electronic drive synchronization free of wear

Characteristic

Every operating point below the shown characteristic curve is possible by a set point of speed.

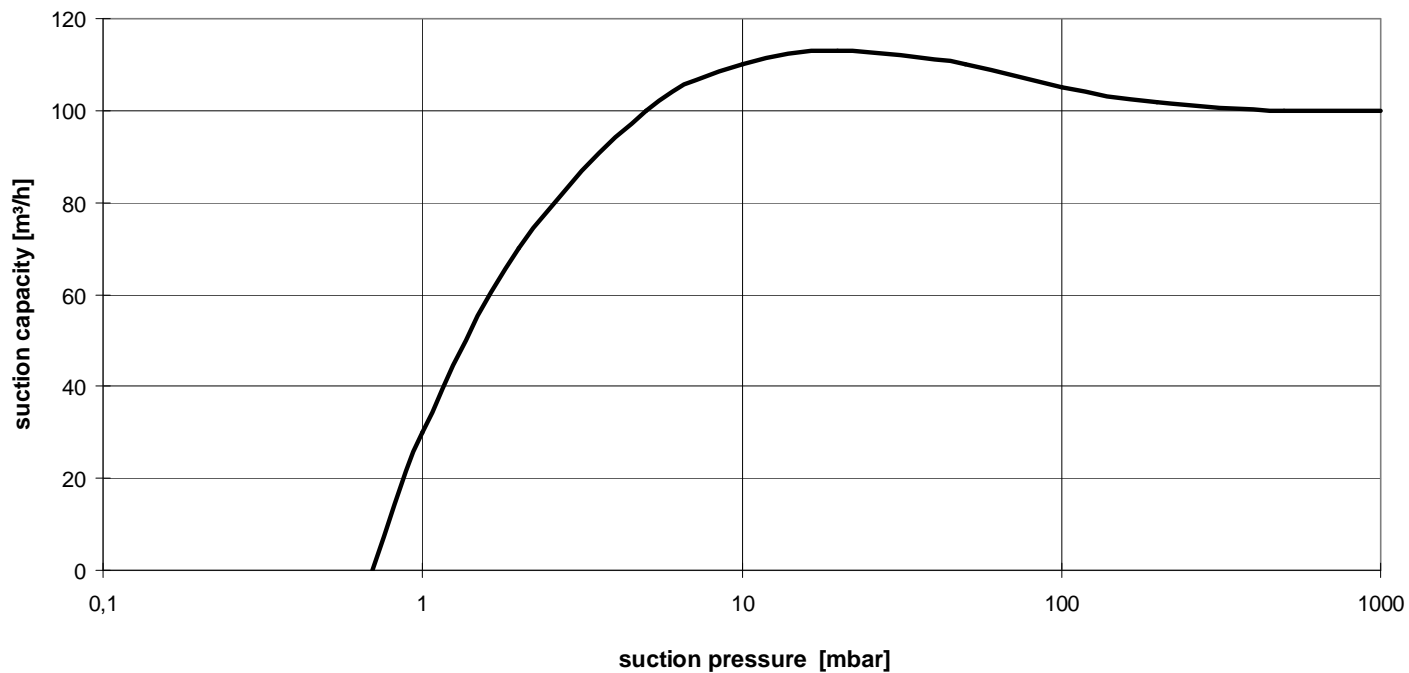

Sectional drawing

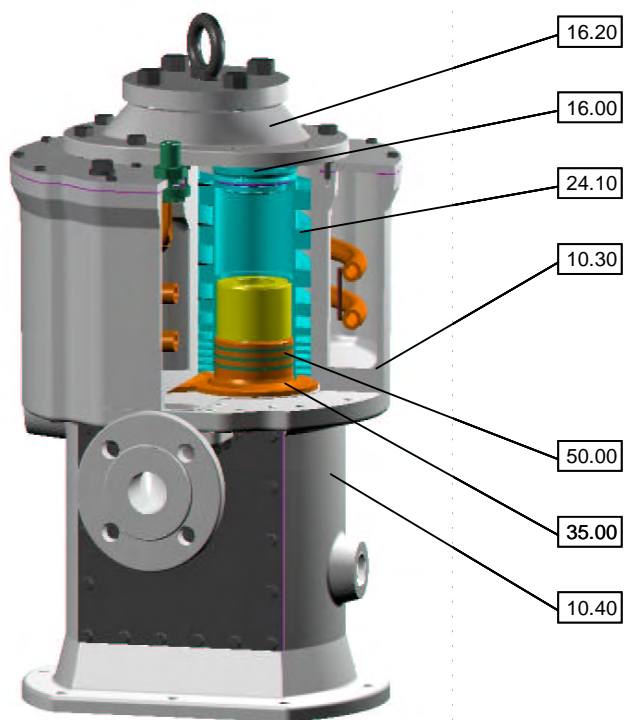

Materials

Item	Construction part	Material
10.30	Casing	GGG 40.3
10.40	Motor casing	GGG 40.3
16.20	Casing cover	GGG 40.3
24.10	Displacement body	1.4122
16.00	Cover	1.4122
35.00	Bearing cartridge	1.4122
50.00	Shielding gas throttle	GG 25

COOLING MECHANISM

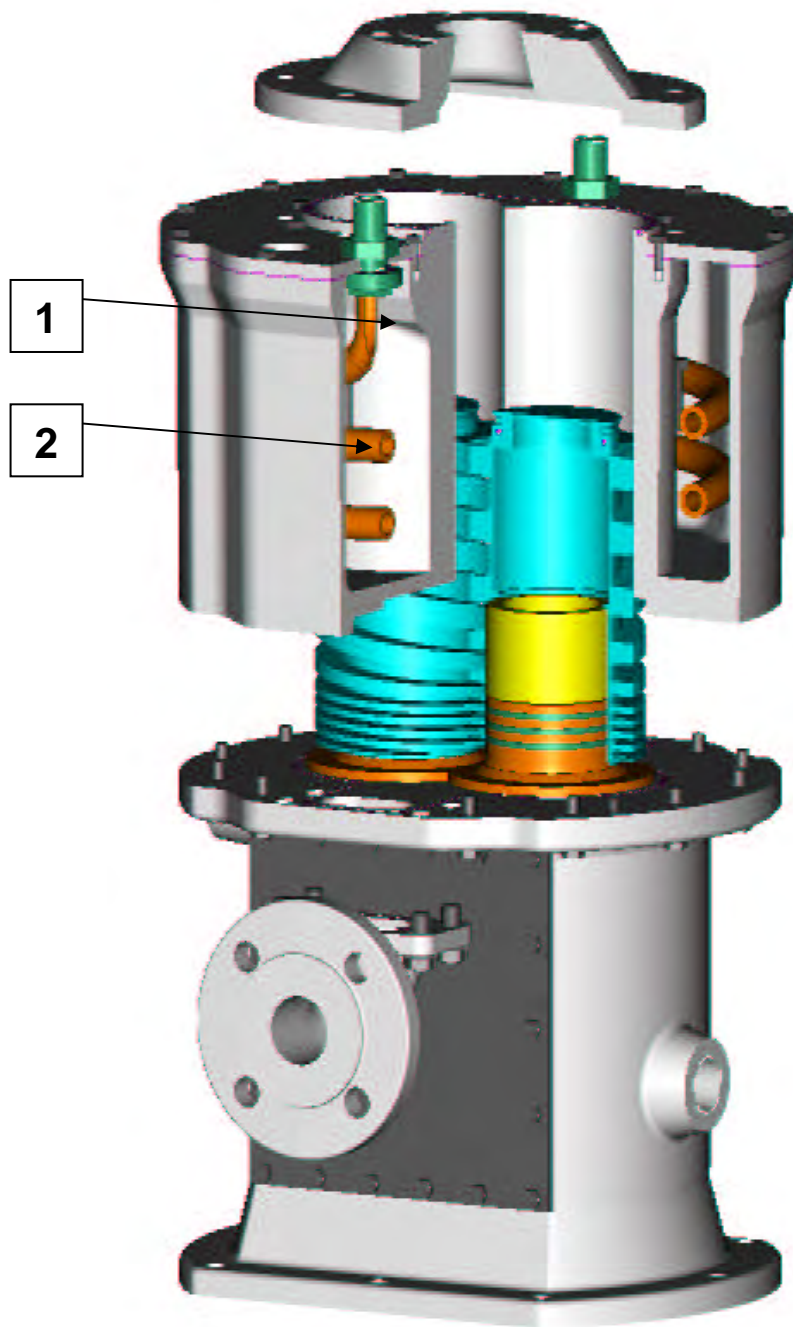

Indirect cooling of the working chamber:

- 1** **cooling water ring**
- 2** **indirect cooling by a cooling loop**

SCOPE OF DELIVERY

The basic design of **SIHIdry** incorporates static FEP O-Ring type casing seals along with the following components:

- Drive electronics fitted in the connecting casing
- Cooling water circuit for cooling of the pump casing, drive motors, and twin-screws
- Suction strainer in order to avoid detrimental particle ingress into the pump.

VARIATION IN DRIVE CONTROL

BASIC

Includes:

- **Fixed speed**
- AC supply
- Input: start/stop
- Input: reset of failure
- Output: operation/failure
- Serial interface

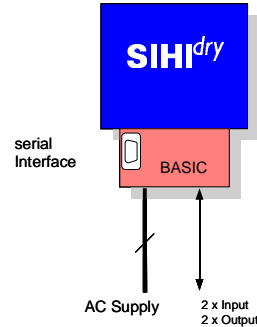

DYNAMIC

For the adaptation of the suction capacity to the actual requirement.

Includes:

- **Variable speed**
- AC supply
- Input: start/stop
- Input: reset of failure
- Analogue input: set value
- Output: operation/failure
- Serial interface

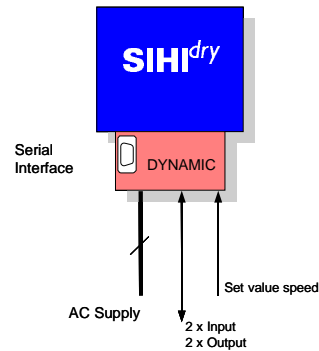

CONTROL

Fully integrated into the system, this control provides some essential process and operating features. These include: Warm up cycles; vacuum switching on/off; flushing for clean in place; N2 purging; and other external trips that can be hard wired into the system such as level and/or temperature gauges, etc. Importantly, the control does not require any further programming nor logic by the customer.

Moreover a vacuum regulation in a range from 0-100% can be realised.

Following signals are available:

- Digital status signals (vacuum operation, warning, stand-by, emergency stop, if necessary cleaning)
- Analogue signals (torque, speed, and, if necessary the suction pressure and different temperatures)
- Digital set points (start, stop, vacuum operation, and, if necessary cleaning)
- Analogue set points (pressure, speed)

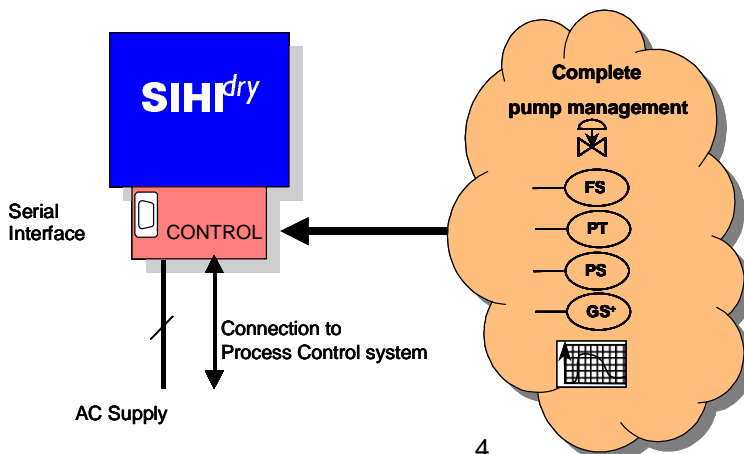

OPTIONAL ACCESSORIES

Module Purge Gas Ex

The standard EExP gas system regulates, controls, and monitors the inert N2 pressure at the shaft seal. It permits the unit to be installed within a hazardous area according to the ATEX – directive. The system is completely integrated and parameterised.

Secondary Cooling Water Circuit

Complete with circulating pump, flow indicator, pressure accumulator, adjustment valves, thermostatic control valve, and heat exchanger; this extensive option is fully integrated into the base-plate. This is particularly useful in areas where site cooling water feed and return lines have very low differential pressures, and is normally very poor quality. Closed loop cooling allows the flow to be accurately regulated from full flow conditions for effective cooling, down to zero flow for effective heating.

Suction Valve Module

This module allows the pump to be isolated from the process at desired times. An example may be whilst the pump reaches pre-determined temperature, or rises above maximum temperature thresholds for selected organic (T4) media. This is carried out via a pneumatically operated suction line valve that is fully integrated within the CONTROL drive variant. Also, in standby situations, the valve avoids reverse flow through the unit whilst connected into common vacuum lines.

Outlet Valve Module

This module enables the safe shutoff of the **SIHI^{dry}** at the suction side from the recipient by means of a pneumatically driven valve. The penetration of residual media into the pump as well as the return flow of exhaust gas through the pump into the recipient are avoided. The control of the valve is taken over by the electronics of the **SIHI^{dry}** when the CONTROL drive variant is used.

Clean in Process Module

Perfectly suited to processes that employ polymerising, subliming, or basically sticky substances, this module allows automatic flushing from a solvent drum. Moreover, with an Angular Difference reading available from the pump, the operator can monitor the extent of any build up in order to optimise cleaning. The flushing valve can also be used for N2 purging in order to provide an inert atmosphere within the machine after it has been stopped, and allowed to cool. This module is fully integrated into the **SIHI^{dry}** when CONTROL drive variant is used.

Flame Arrester Module

Certified and tested in accordance with ATEX for use in both Zone 1 and Zone 0 process atmospheres, deflagration and detonation arresters can provide extra safety.

Temperature Measurement Module

By integrating temperature transmitters into the system, this module provides additional vacuum pump safety and recording.

Pressure Measurement Module

This module allows the measurement of different process pressures within the vacuum system. This module is fully integrated into the **SIHI^{dry}** when drive variant CONTROL is used.

Operator Indicator Panel Module

Available when the drive variant CONTROL is requested, the panel provides the operator with a simple visual indication of the pump parameters. Characteristics like speed, pressure, torque, temperature, and the important angular difference, are available from a simple push button menu, and can be seen within the LCD.

PARA^{dry} Parameter Modification Module

Eliminating the need to employ PLC programmers, the **PARA^{dry}** software enables the principle process engineer to modify specific pump parameters. Such parameters are at the discretion of the customer and may include max/min temperature boundaries, speed and pressure, settings, warm up cycles, etc. providing long term future running adaptability, a standard windows based computer is needed.

FLOW DIAGRAM

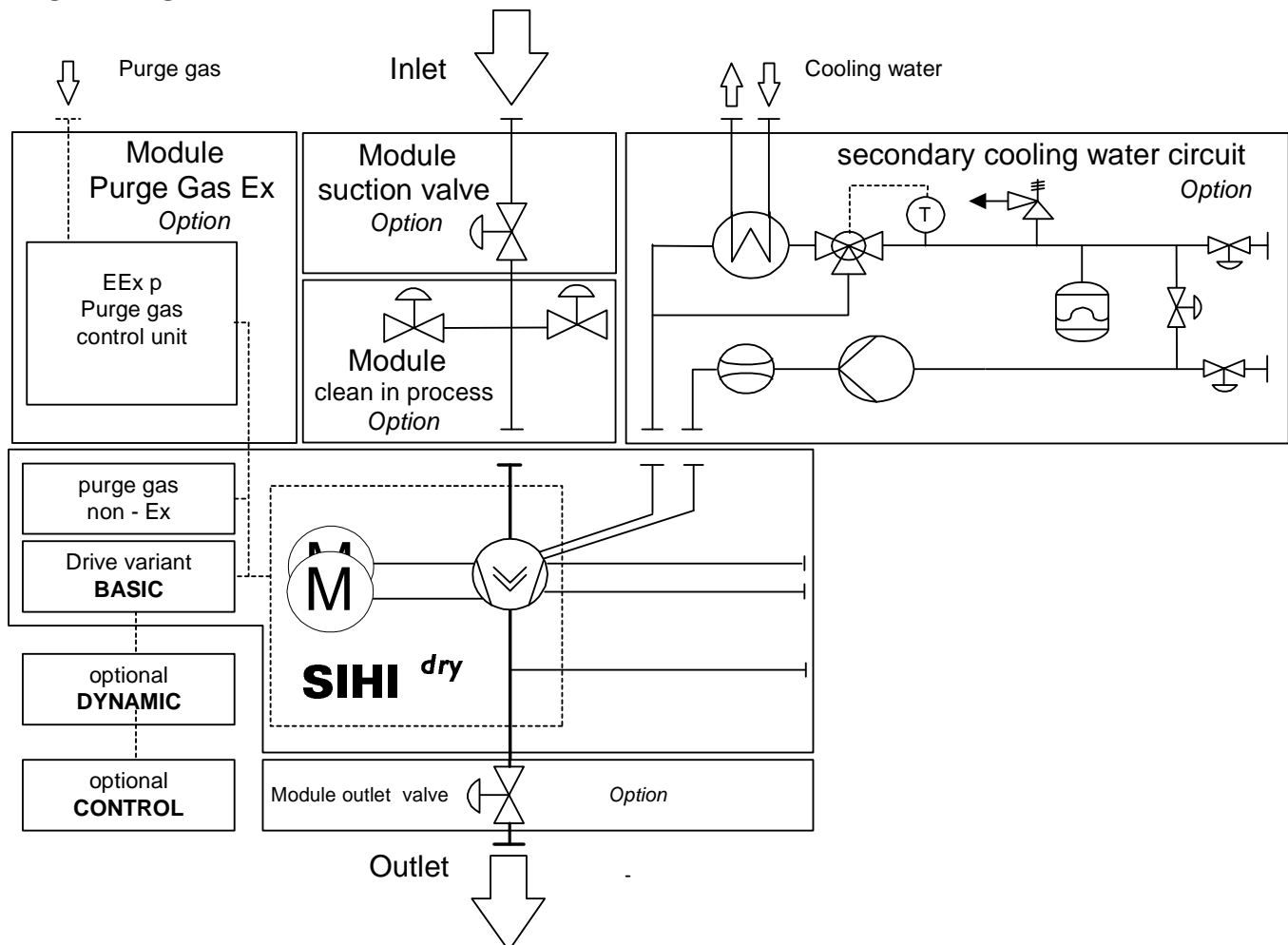

DIMENSION TABLE

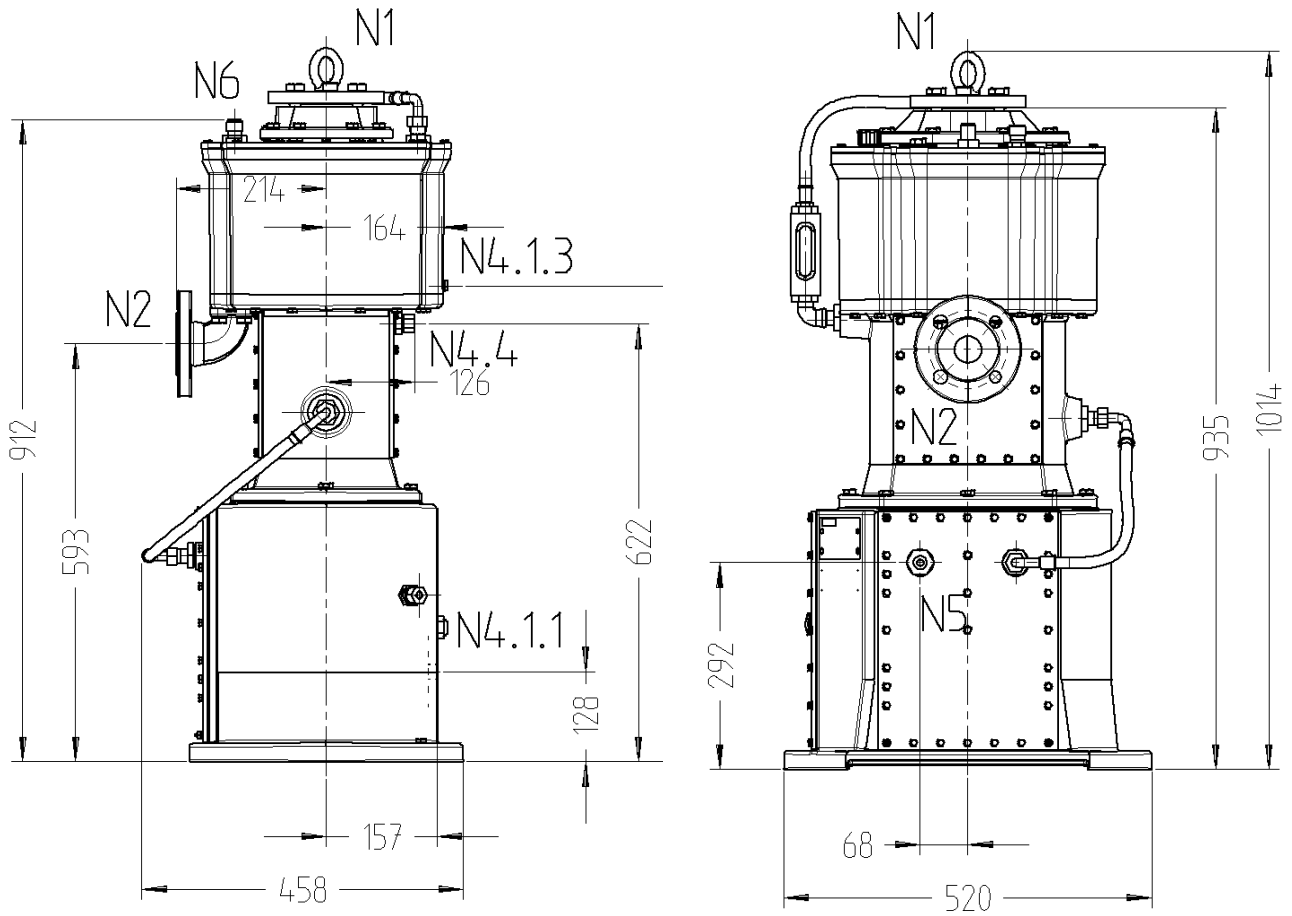

Benennung designation description	DN	PN	Anschlussmaße / Dichtflächen connecting dimensions/sealing surfaces mesures de connexion / surfaces d'étanchéité
N1 Einlass inlet entrée	50	16	gebohrt nach DIN 2501 4x ϕ 18 / DIN 2526 Form C
N2 Auslass outlet sortie	40	16	DIN 2633 4x ϕ 18 / DIN 2526 Form C
N4.1.1 Sperrgas Einlass purgig gas inlet entrée gaz de purge	G 1/2"		Innengewinde
N4.1.3 Anschluss fuer optionale Gasverduennung connection for optional gas dilution connexion de rarefaction de gaz sur demande	G 1/4"		Innengewinde
N4.4 Sperrgas Auslass purgig gas outlet sortie gaz de purge	ϕ 12		Rohr
N5 Kuehlfluessigkeit Einlass / Vakuumpumpe cooling liquid inlet / vacuum pump entrée refroidisseur / pompe a vide	G 1/2"		Aussengewinde
N6 Kuehlfluessigkeit Auslass / Vakuumpumpe cooling liquid outlet / vacuum pump sortie refroidisseur / pompe a vide	G 1/2"		Aussengewinde

