

Dry running vacuum pumps



SIHI^{dry} S100

GENERAL TECHNICAL DATA

Suction capacity	100 m ³ /h
Final pressure	< 0,7 mbar abs
Power consumption at final pressure	2,5 kW
Cooling water T _{min}	+ 10°C
Cooling water T _{max}	+ 35°C
Sound level as per DIN ISO 9614 / 21680	< 54 dB(A)
Weight	ca. 260 kg

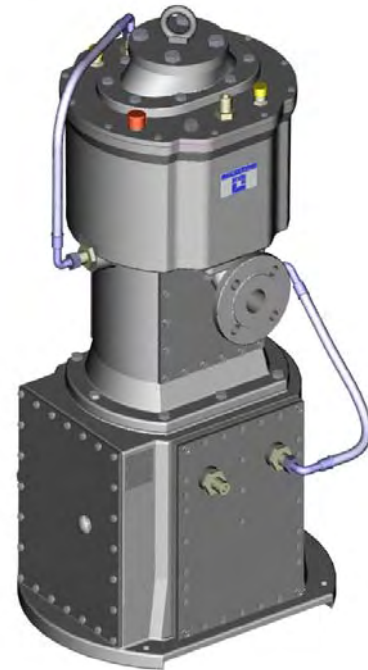

CONSTRUCTION TYPE

The vacuum system SIHI^{dry} S100 has been especially developed for use in industrial applications. It is based upon a dry running twin screw principle, which is without any lubricants, sealants or operating liquids.

Wide clearances in the pumping chamber make the pump robust when it comes to the handling of particles and liquids. It is supported by top-down pumping (inlet at the top and the outlet at the lowest point in the pumping chamber) and the pump chamber has been designed to eliminate dead space.

The cantilever drive shaft arrangement allows the pump casing to be easily assembled without removing the bearing. If the pump chamber needs to be cleaned then it can be carried out on site by the operator's own personnel.

The labyrinth shaft seals operate without contact and are therefore wear free.

In contrast to conventional pumps both screw spindles are electronically synchronised rather than by mechanical means.

This innovative drive means that monitoring and filling of gear oil is not required and the drive design results in the vacuum pump being extremely quiet.

DESIGN

The flexibility of the modular system allows it to adapt to any process conditions. Thus the innovative drive concept and its optional additional features, such as the regulation of the speed to meet the requirement of the system, offers the possibility to considerably reduce the power absorption.

At the same time if it is necessary to control the valves for the purging of the pump, this can be done by the vacuum system itself. Furthermore the intelligent system offers the possibility to accurately monitor the important process data. This is to ensure safety is maximised and to recognise any deviations in good time so as to take appropriate counter measures.

PROPERTIES

- No gear or transmission lubricant, neither in the pumping chamber nor in the gear
- Problem-free handling of particles and liquids
- Rapid disassembly of the pump chamber without removing the bearing.
- Shaft seals are contact free & wear free
- Silent electronic drive
- Possibility of error detection with remote data transmission

Characteristic

Every operating point below the given characteristic curve is possible with the drive variant DYNAMIC by the input of the speed set point (down to the minimum speed).

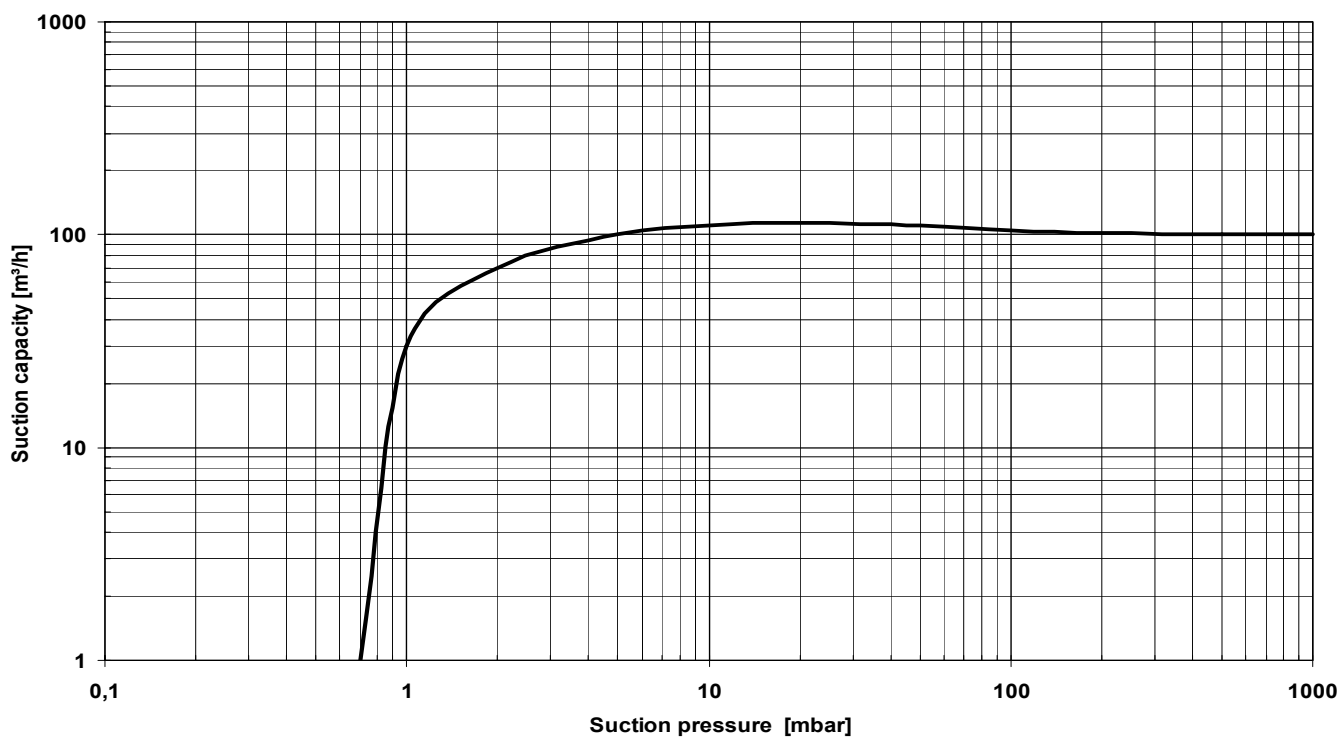

Sectional drawing

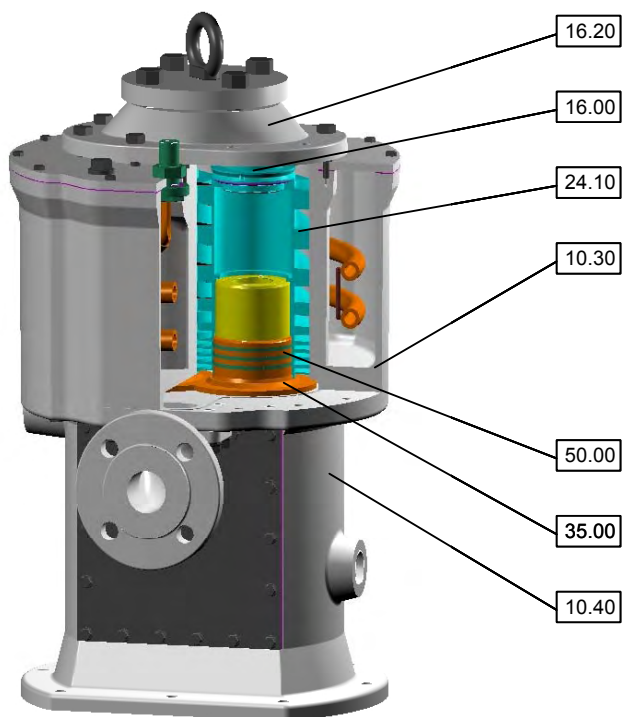

Materials

Item	Construction part	Material
10.30	Casing	GGG 40.3
10.40	Motor casing	GGG 40.3
16.20	Casing cover	GGG 40.3
24.10	Twin screw spindle	1.4122
16.00	Cover	1.4122
35.00	Bearing cartridge	1.4122
50.00	Shielding gas throttle	GG 25

Cooling mechanism

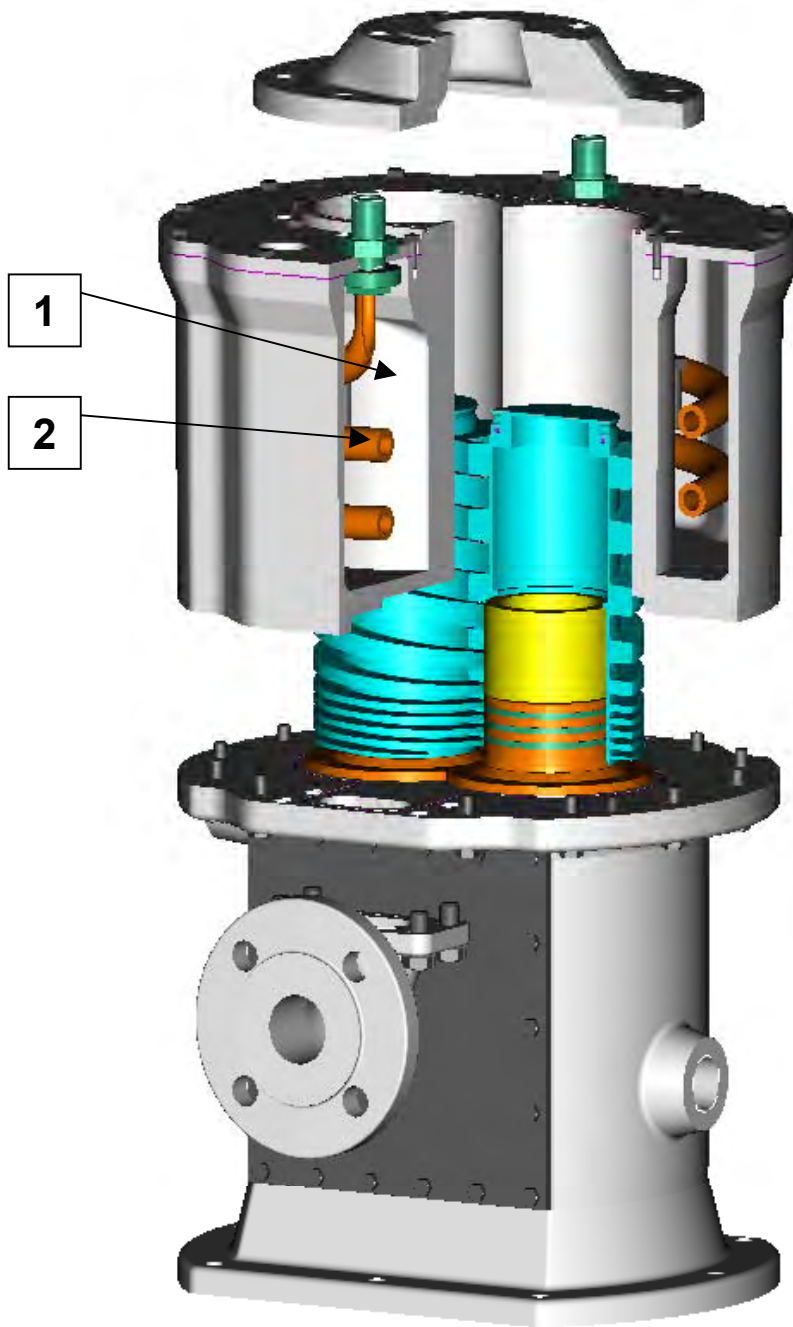

Indirect cooling of the working chamber:

- 1** **Cooling water ring**
- 2** **Indirect cooling by a cooling loop**

Scope of delivery

The scope of delivery for the basic design of the compact vacuum system incorporates SIHI^{dry} with the casing sealing made out of Viton and the following system components:

- Drive electronics mounted in the connecting casing
- Cooling water circuit for cooling of the drive motors as well as the pump casing

Variants of drive control

BASIC

includes:

- Fixed speed
- AC Supply
- Serial interface for service

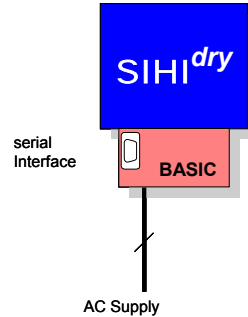

DYNAMIC

For the adaptation of the pump speed to the actual requirement

Includes:

- Variable speed
- AC supply
- Input: Start/stop
- Input: Reset of failure
- Analogue input: Set value
- Output: Vacuum operation, failure/no failure
- Serial interface for service

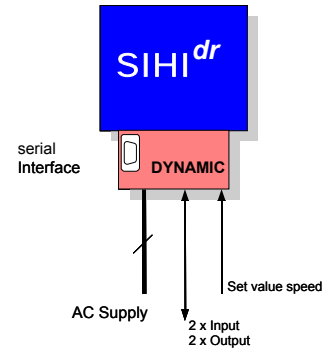

CONTROL

In addition to DYNAMIC, the drive variant CONTROL includes the automatic adaptation of the speed to the set point pressure value and thus enables an optimum regulation of the vacuum. Furthermore the drive variant CONTROL offers the automatic valve control and the appertaining logics for process-specific functions e.g. cleaning, standby etc.

Following signals from the PCT are available:

- Digital set points (start, stop, vacuum operation, cleaning)
- Analogue set points (pressure or speed)
- Digital status signals (operation, vacuum operation, cleaning mode, no failure, warning, failure)
- Analogue signals (torque, speed and if required: suction pressure, temperature)

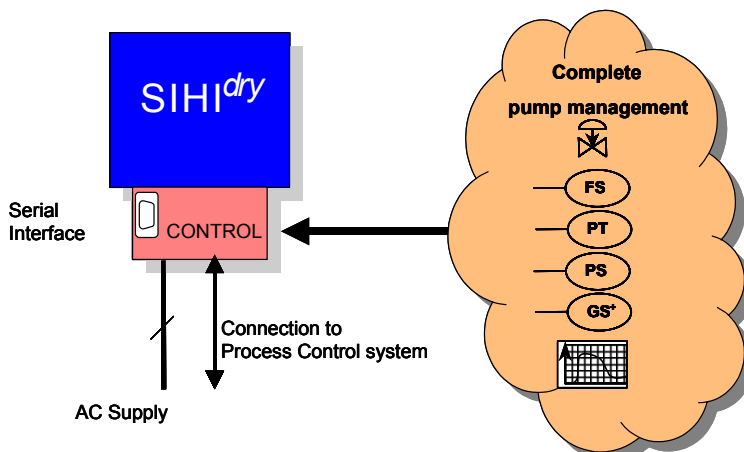

Optional Accessories

Module secondary cooling circuit

Closed cooling circuit with rotary pump and heat exchanger mounted on the base frame in order to accurately and independently adjust the working temperature, even under changing conditions. It is installed with a thermostatic control valve.

Shut off module at suction side

This module allows the safe shut-off of the SIHI^{dry} on the suction side by means of a pneumatically driven valve. The penetration of residual media into the pump as well as the return flow of exhaust gas through the pump into the process is avoided. The control of the valve is managed by the electronics of the SIHI^{dry} when the CONTROL drive variant is used.

Module outlet valve

This module allows the safe shut-off of the SIHI^{dry} on the outlet side from the exhaust network by means of a pneumatically driven valve. The penetration of residual media into the pump as well as the return flow of exhaust gas through the pump is avoided. The valve is controlled by the electronics of the SIHI^{dry} when the CONTROL drive variant is used.

Module gas purge / liquid cleaning

This is a valve combination for liquid cleaning in case of sticky or dusty processes and a valve for the N₂ purge to provide an inert atmosphere or drying of the pumping chamber after the pump stops. The valves are fitted and when using the drive variant CONTROL option, it is also electrically controlled by the SIHI^{dry}.

Module temperature measurement

This module enables the recording / collecting of temperatures by the integration of defined temperature transmitters into the vacuum system.

Module pressure measurement

This module measures different process pressures within the SIHI^{dry} vacuum system. The evaluation of the pressure values is controlled by the SIHI^{dry} when the CONTROL drive variant is used.

Parameter- and diagnosis software PARA^{dry}

Visualisation and the short-term storage of operating data and pump monitoring data. This software can be installed in a standard PC or Laptop.

DIMENSIONS

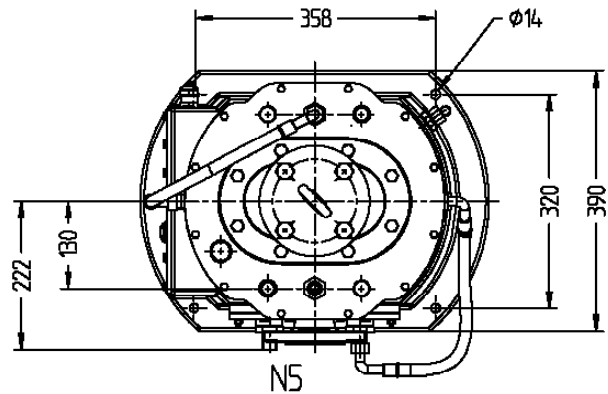
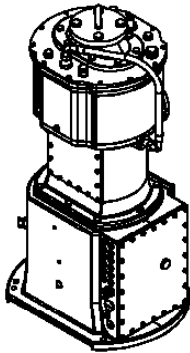
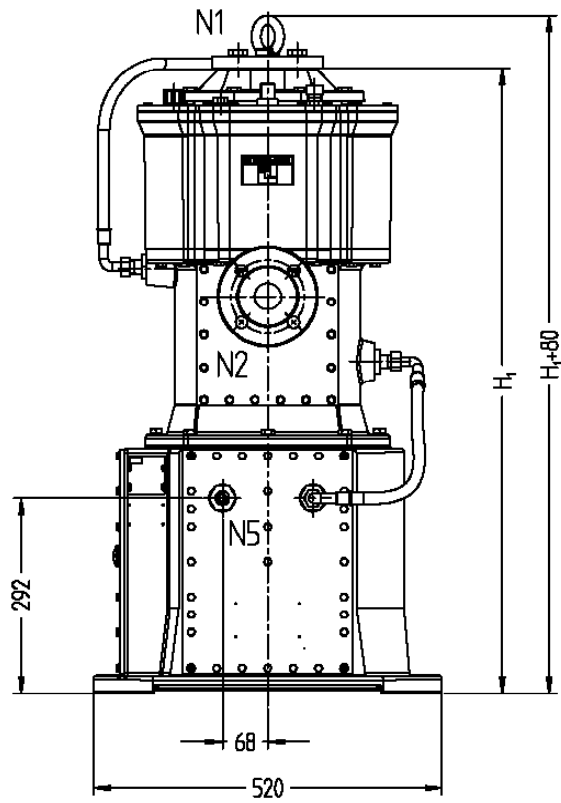
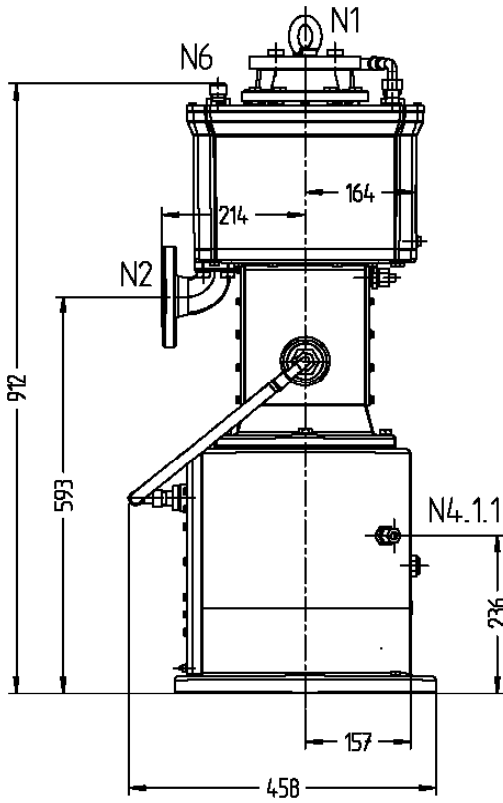

Location / Size of connections

Inlet	N1	DN50 PN16 (4xM16) EN 1092-2 form B (as per DIN 2501)
Outlet	N2	DN40 PN16 (4x Ø18) EN 1092-2 form B (as per DIN 2501)
Purge gas inlet	N4.1.1	Compression fitting (Ermeto) for pipe Ø12mm
Coolant inlet	N5	G ½" External screw thread
Coolant outlet	N6	G ½" External screw thread

Pump Dimensions

Length	approx.	458mm
Width	approx.	520mm
Hight H ₁	approx.	935mm

Sterling SIHI GmbH

Lindenstraße 170, 25524 Itzehoe, Germany, Phone +49 (0) 48 21 / 7 71 - 01, Fax +49 (0) 48 21 / 7 71 - 274