

Liquid ring vacuum pumps

in compact design



LEM 26, LEM 51

Pressure range: 33 to 1013 mbar
Suction volume flow: 3 to 58 m³/h

CONSTRUCTION TYPE

SIHI liquid ring vacuum pumps are displacement pumps of uncomplicated and robust construction with the following particular features:

- non-polluting due to nearly isothermal compression
- oil-free, as no lubrication in the working chamber
- handling of nearly all gases and vapours
- small quantities of entrained liquid can be handled
- easy maintenance and reliable operation
- low noise and nearly free from vibration
- wide choice of material, therefore applicable nearly everywhere
- protection against cavitation as standard
- incorporated dirt drain
- incorporated central drain
- no metallic contact of the rotating parts

The SIHI liquid ring vacuum pumps LEM are single-stage ones.



NOTE

During operation the pump must continuously be supplied with service liquid, normally water, in order to eliminate the heat resulting from the gas compression and to replenish the liquid ring, because part of the liquid is leaving the pump together with the gas. This liquid can be separated from the gas in a liquid separator (see catalogue part accessories).

It is possible to reuse the service liquid. The pumps are equipped with a device by which the contaminated service liquid can continuously be drained during operation (dirt drain), if necessary.

The direction of rotation is clockwise, when looking from the drive on the pump.

APPLICATION

Handling and exhausting of dry and humid gases; entrained liquid can be handled during normal duty. The pumps are applied in all fields where a pressure of 33 to 900 mbar must be created by robust vacuum pumps.

GENERAL TECHNICAL DATA

Pump type	unit	LEM 26	LEM 51
speed	50 Hz 60 Hz		2900 3500
Max. compression over pressure	bar		0,3
Max. admissible pressure difference	bar		1,1
Hydraulic test (over pressure)	bar		3
Moment of inertial of the rotating pump parts and of the water filling	kg · m²	0,003	0,005
Sound pressure level at a suction pressure of 80 mbar	dB (A)		68
Max. gas temperature	dry °C saturated °C		200 100
Service liquid			
max. admissible temperature	°C		80
max. viscosity	mm²/s		4
max. density	kg/m³		1200
volume up to shaft level	liter	0,4	0,6
Max. flow resistance of the heat exchanger	bar		0,2

The combination of several limiting values is not admissible.

Material design

Item	COMPONENTS	MATERIAL DESIGN	
		0A	4B
10.10	Casing	0.6025	1.4408
13.70	Guide disk	1.4404	
16.10	Cover	1.4404	
23.50	Vane wheel impeller	2.1096.01	1.4517
43.30	Standard mechanical seal	Cr-steel / carbon / Perbunan	Cr Ni Mo-steel / carbon / Viton
75.11	Valve plate	PTFE	

Sectional drawing LEM 26, LEM 51

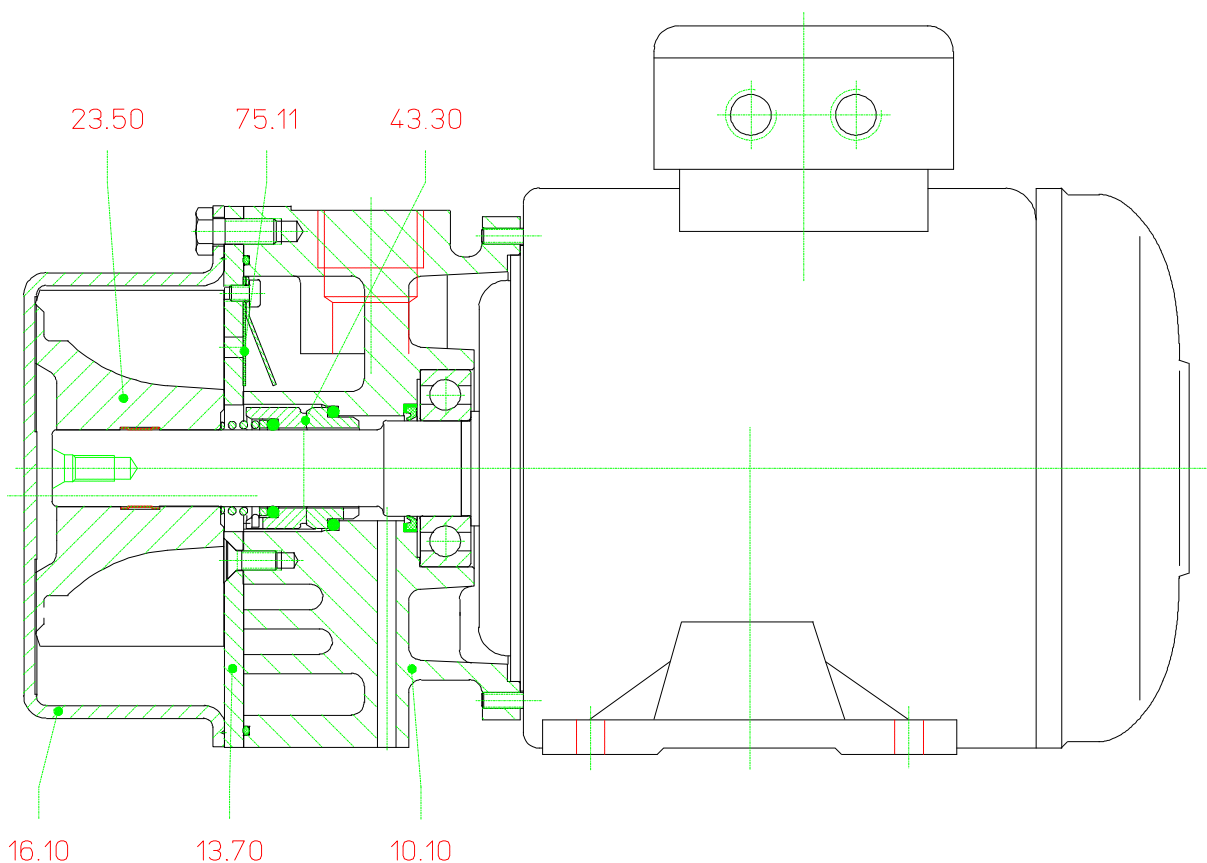

Fresh water requirements in [m³/h] dependent on suction pressure, speed, mode of operation and difference in temperature

suction pressure [mbar]		33					120					200					400				
pump	speed [rpm]	KB			FB	KB			FB	KB			FB	KB			FB				
		difference in temperature [°C]				difference in temperature [°C]				difference in temperature [°C]				difference in temperature [°C]							
		10	5	2		10	5	2		10	5	2		10	5	2					
LEM 26	2900	0,04	0,07	0,14	0,39	0,05	0,09	0,16	0,36	0,05	0,09	0,15	0,3	0,05	0,08	0,14	0,28				
	3500	0,06	0,10	0,18		0,07	0,11	0,19		0,07	0,11	0,18									
LEM 51	2900	0,07	0,13	0,23	0,48	0,09	0,15	0,24	0,42	0,09	0,14	0,23	0,36	0,09	0,14	0,22	0,34				
	3500	0,11	0,17	0,28		0,12	0,19	0,28		0,12	0,18	0,26									

FB = fresh liquid service

KB = combined liquid service with service water 10 °C, 5 °C, 2 °C warmer than the fresh water.

Suction volume flow and power absorption LEM 26

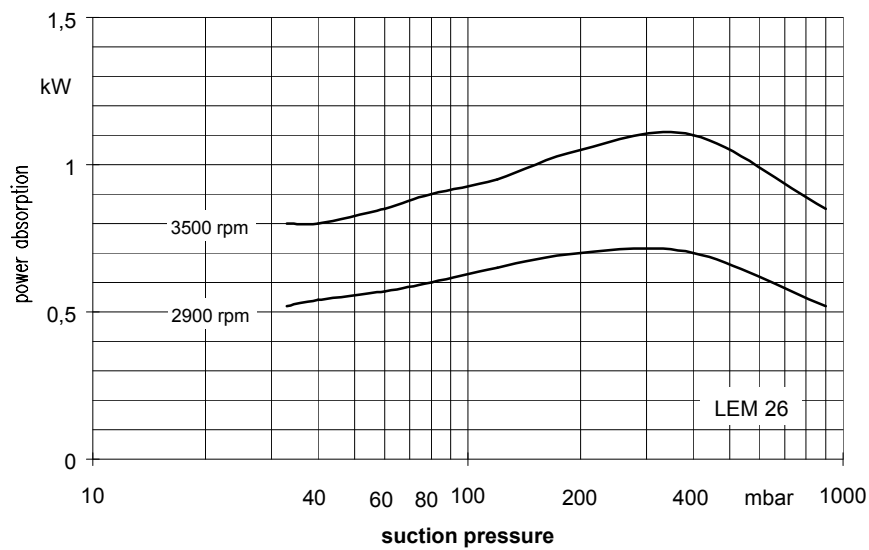
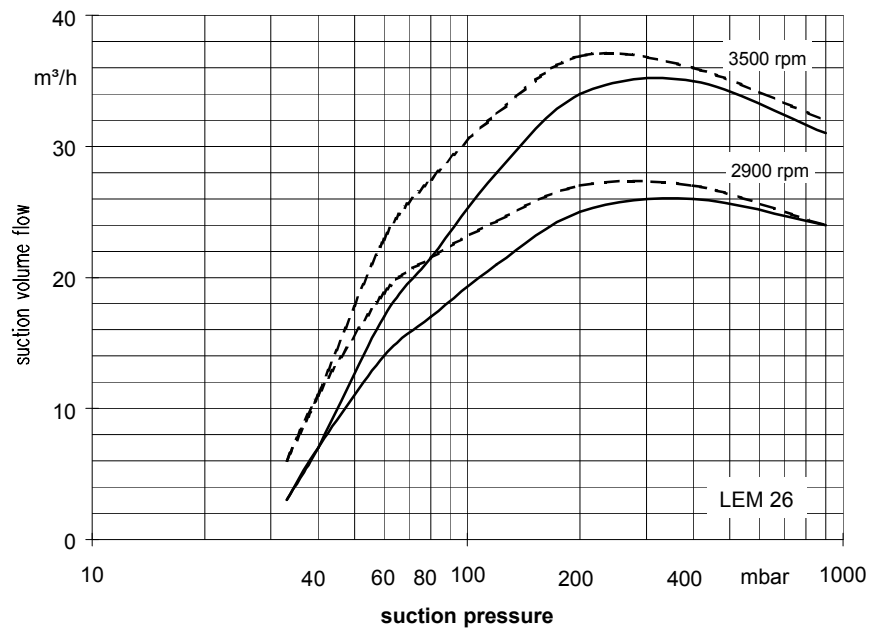

The operating data are applicable under the following conditions:

- pumping medium:
 - dry air: 20°C —————
 - water vapour saturated air: 20°C - - - - -
- service liquid:
 - water: 15°C

Compression pressure 1013 mbar (atmospheric pressure)

The suction volume flow is applied to the suction pressure

Tolerance of the operating data 10%

Max. fresh water need with lowest suction pressure

Suction volume flow and power absorption LEM 51

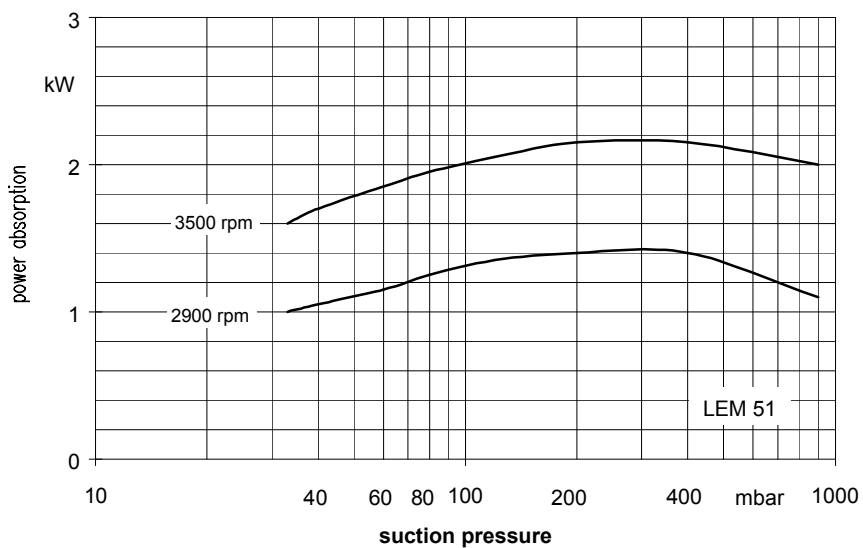
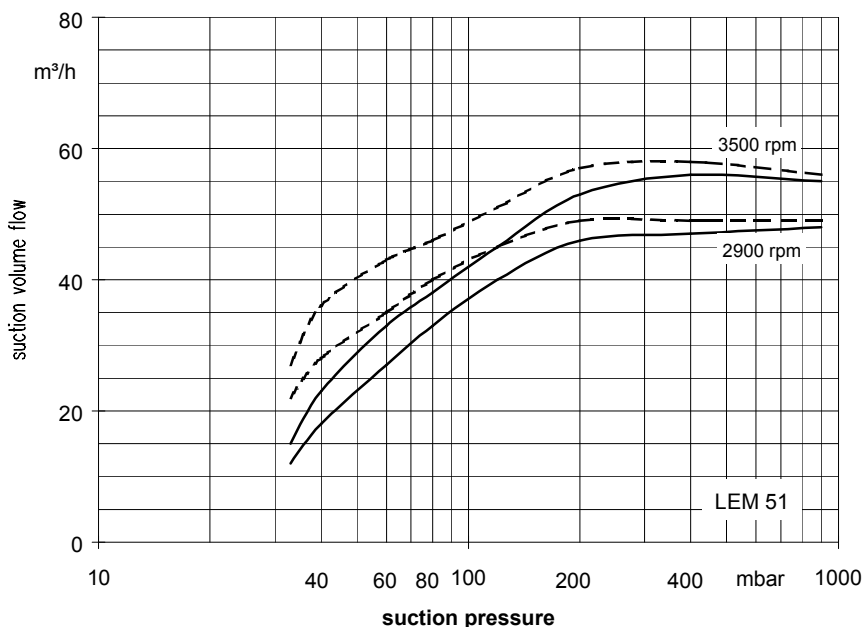

The operating data are applicable under the following conditions:

- pumping medium:
 - dry air: 20°C _____
 - water vapour saturated air: 20°C - - - - -
- service liquid:
 - water: 15°C

Compression pressure 1013 mbar (atmospheric pressure)
 The suction volume flow is applied to the suction pressure
 Tolerance of the operating data 10%
 Max. fresh water need with lowest suction pressure

Dimension table LEM 26

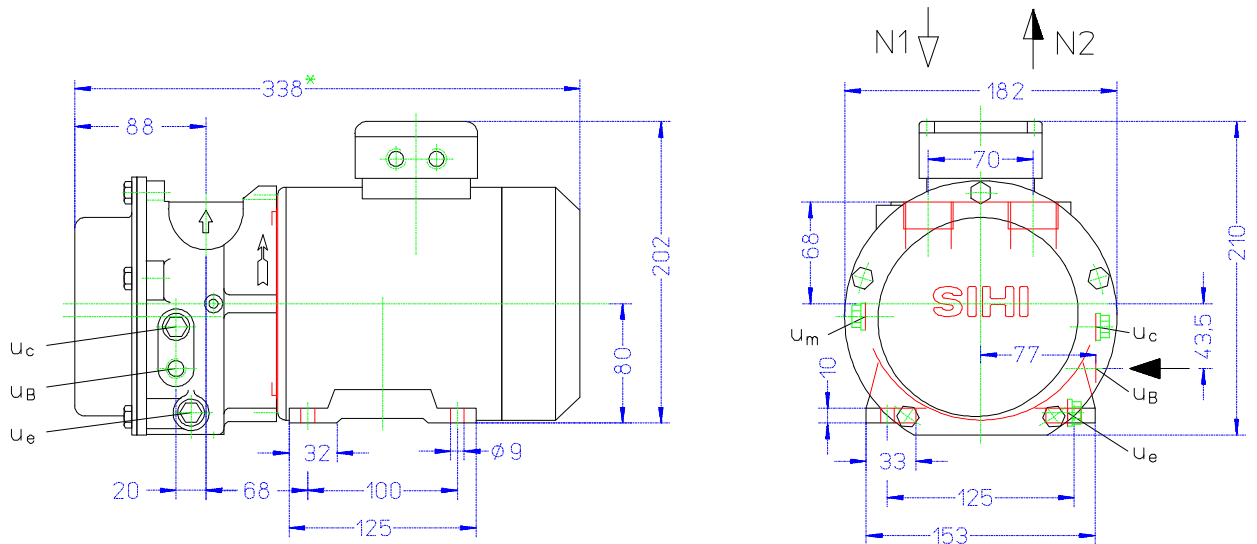

	electric motor IP 55		weight abt. kg
	size	kW	
LEM 26	80	50 Hz	60 Hz
		0,75	1,1

other motors on request

* dimension dependent on the motor make

- N 1 = gas inlet G 1
- N 2 = gas outlet G 1
- U_B = connection for service liquid G ¼
- U_c = connection for protection against cavitation G ¼
- U_e = drain connection G ¼
- U_m = connection for pressure gauge G ¼

Dimension table LEM 51

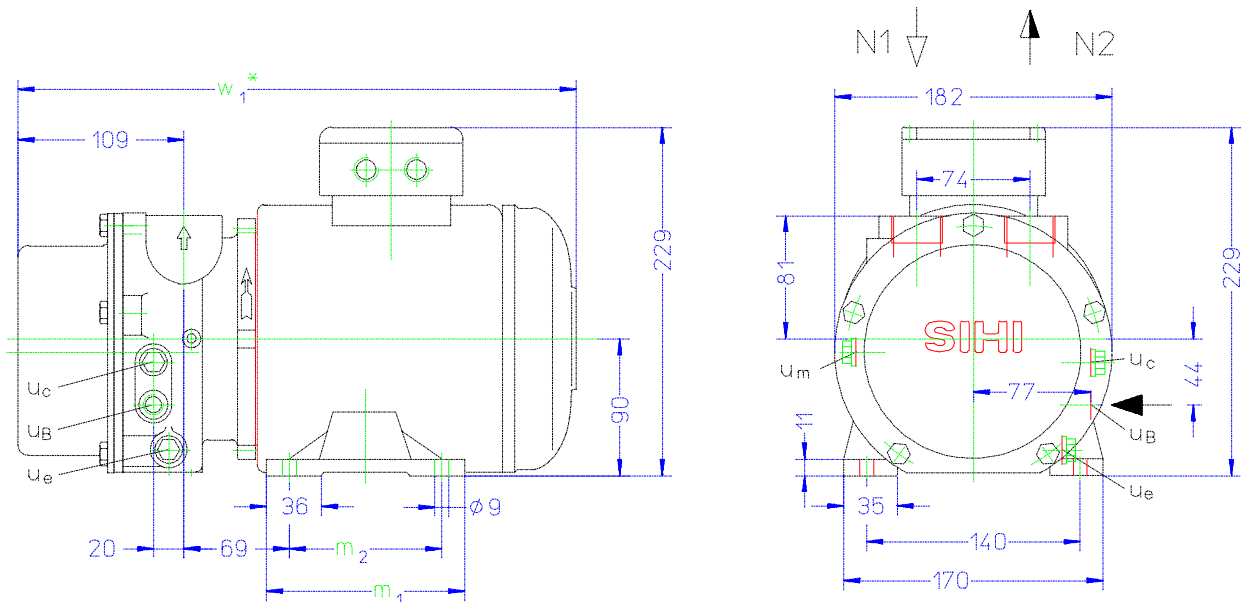

	size	electric motor		m ₁	m ₂	w ₁ *	weight abt. kg
		50 Hz	60 Hz				
LEM 51	90 S	1,5	-	130	100	366	27
	90 L	-	2,2	155	125	391	30

other motors on request

* dimension dependent on the motor make

- N 1 = gas inlet G 1
- N 2 = gas outlet G 1
- U_B = connection for service liquid G ¼
- U_c = connection for protection against cavitation G ¼
- U_e = drain connection G ¼
- U_m = connection for pressure gauge G ¼

Arrangement drawing LEM 26, LEM 51

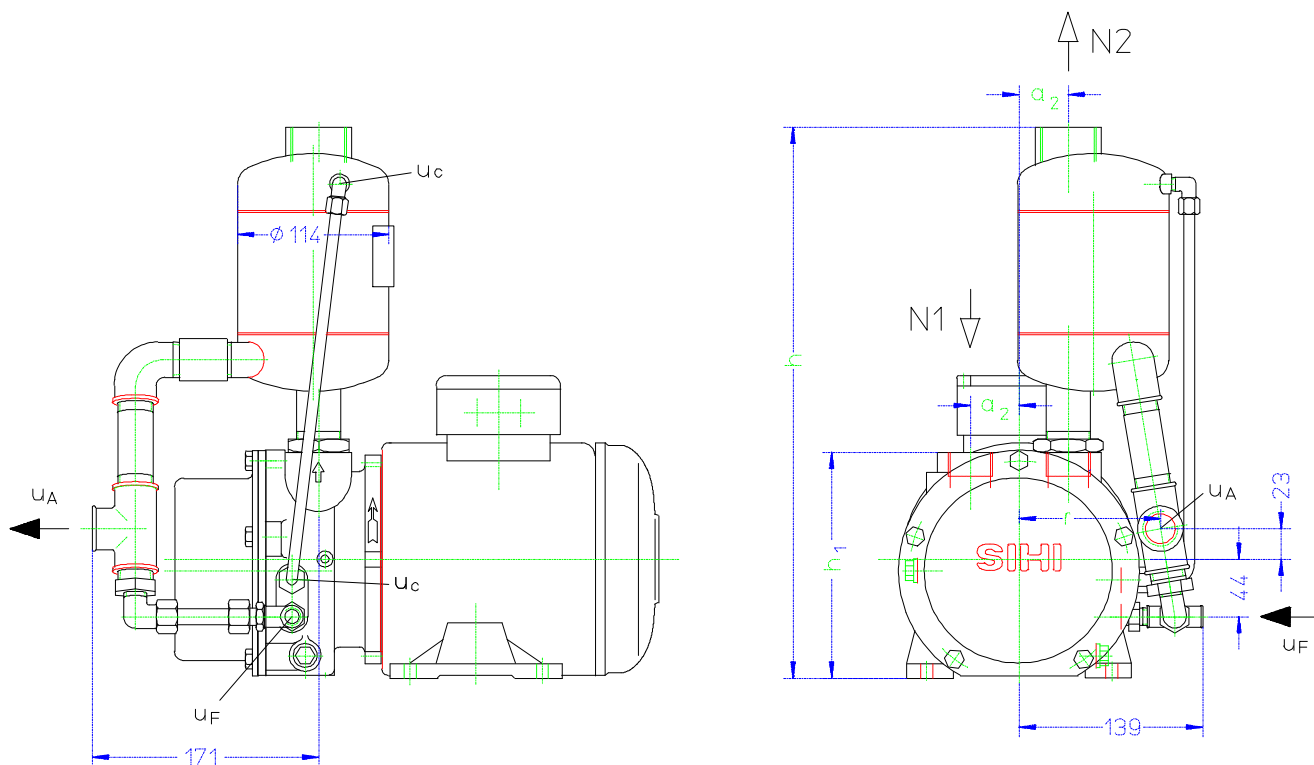

	electric motor IP 55		a ₂	h	h ₁	r	weight abt. kg
	size	50 Hz					
LEM 26	80	0,75	1,1	35	394	105	24
LEM 51	90 S	1,5	-	37	417	171	30
	90 L	-	2,2				33

- N 1 = gas inlet G 1
- N 2 = gas outlet G 1 1/4
- u_A = connection for liquid drain G 3/4
- u_F = connection for fresh liquid G 1/4
- u_c = connection for protection against cavitation G 1/4

Data regarding the pump size - order hints

series + size	hydraulics + bearings	shaft sealing	material design	casing seal
	A • hydraulick A •Z two grease lubricated antifriction bearing arranged in the motor	AAE mechanical seal O-rings Perbunan AA1 as AAE, but O-rings Viton	0A main parts GG 4B main parts Cr Ni Mo-cast steel	7 O-rings Teflon cord
LEM 26	AZ	AAE. AA1	0A. 4B	7
LEM 51				

Motor selection table

	motor enclosure IP 55 50 Hz					motor enclosure IP 55 60 Hz				
	Y-voltage V +/- 5%	Δ-voltage V +/- 5%	power kW	size	motor- design.	Y-voltage V +/- 5%	Δ-voltage V +/- 5%	power kW	size	motor- design.
LEM 26	346-440	200-254	0,75	80	AW	346-480	200-277	1,1	80	BW
LEM 51	346-440	200-254	1,5	90 S	AW	346-480	200-277	2,2	90 L	BW

Example for ordering:

The construction size LEM 26 AZ AAE 0A 7 with 0,75 kW three-phase ac motor (50 Hz, 230 VΔ) 2900 rpm has the complete order number:

LEM · 26 AZ AAE 0A 7 AW

If motors with the other voltage or frequency are required a special information should be given.

On delivery the point (•) in the fourth place of the type code is replaced by a letter in the factory.

Accessories LEM 26, LEM 51

Recommended accessories		LEM 26	LEM 51
Overhead liquid separator	type	XBa 244	
material design	weight	2,8 kg	
	SIHI part No.	35 000 374	
service liquid line		35 000 375	
material design	SIHI part No.	35 009 666	35 009 701
		35 009 662	35 009 700
cavitation protection line	SIHI part No.	20 042 674	
material design		20 042 672	
SIHI-gas ejector			
at service liquid temperature	15 °C	GEV 25 A	GEV 50 A
at service liquid temperature	30 °C	GEV 25 A	GEV 50 A
Ball type non-return valve	size / weight	G 1 / 0,7 kg	
material design	SIHI part No.	20 044 637	
		43 038 310	

Any changes in the interest of the technical development are reserved.

Sterling SIHI GmbH

Lindenstraße 170 , D-25524 Itzehoe, Germany , Telephone +49 (0) 48 21 / 7 71-01 , Fax +49 (0) 48 21 / 7 71-274