

CEB 2000

Closed coupled vertical tank pump

Magnetic drive with special NPSH Impeller for AutoGas filling stations



TECHNICAL DATA

Output	:	max. 65 l/min
Differential pressure	:	max. 16,5 bar
Speed:	:	max. 2900 rpm
Temperature	:	max. - 40 °C to + 60 °C
Casing pressure	:	PN 40
Shaft sealing	:	Sealless magnetic coupling
Flange connection	:	DIN 2501 PN 40
Direction of rotation	:	Anti-clockwise when seen from the drive end
Casing material	:	GGG 40.3 (Nodular Iron)

APPLICATION

Vertical, extended tank pump essentially for handling liquids that are either boiling or stored at their vapour pressure. Particularly suited to AutoGas filling stations.

One of the primary features of this side-channel type of pump is the special suction impeller that requires extremely low levels of NPSH. CEB pumps have been specifically designed for use with Liquefied Petroleum Gas and other liquefied gases.

DESIGN

Sterling-SIHI side channel units are a low noise design of combination pump. They are ideal for pumping liquids that are stored at their boiling point, have a degree of entrained gas, or very low NPSH conditions. The vertical tank pump has been designed in order to enable retro-fitting into most common tanks. Moreover, the dimensions are such that the unit can be used to replace submersible designs of pump.

Although the pump can be supplied in other lengths, the standard size is between 1.3 -& 3.0 m.

CONSTRUCTION

Casing pressure:
Max. 40 bar from -40°C to +60°C.

Please observe:
Technical and safety regulations that apply to installation.
Casing pressure = inlet pressure + delivery pressure at minimum output.

Flange position:
Tank flange vertical, discharge flange horizontal.

Connection:
Flange design to DIN 2534 / PN40 or DIN 2512 with groove. And spring. Other drillings available upon request.

Hydraulics:
Side channel hydraulic with NPSH inducer stage.

Bearing:
Two product lubricated SiC sleeve bearings with plus additional intermediate bearings throughout the extended shaft.

Shaft sealing:
Sealless/Magnetic drive. Power transmission effected by magnetic coupling. Importantly, this is a modular design adapted from our extensive range of sealless pumps.

Casing seal:
The static casing seals are made from soft Teflon.

Drive:
By standard electric motor, IM V1or B5.



Sterling Fluid Systems France

Zone Industrielle de Trappes-Elancourt, 1-3 Avenue Georges Politzer, Boite Postale 41, F-78193 Trappes Cedex, France
Telephone : +33-(0)1348239 00 Fax : +33-(0)1348239 61
www.sterlingfluidsystems.com

- 01.01 top casing
- 0241, 0243 sleeve bearing
- 10.70 discharge casing
- 10.80, 10.90, 11.40 intermediate piece
- 21.00 - 21.03 shaft
- 23.10 impeller
- 23.50 vane wheel impeller
- 31.40 thrust bearing
- 34.60 stool
- 54.01, 54.52 sleeve bearing
- 81.70 isolation shroud
- 84.71 inner magnet
- 84.72 outer magnet

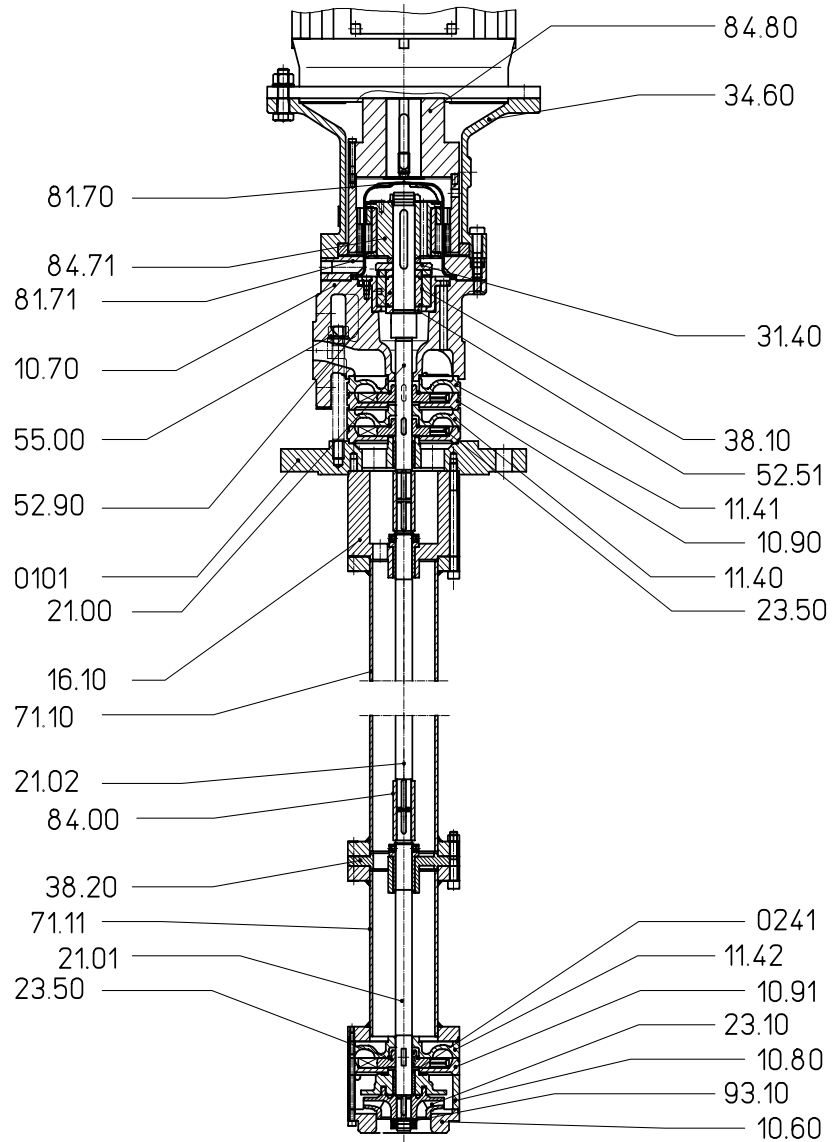

Material design

Item	COMPONENTS	MATERIAL DESIGN	
		1A	1F
01.01	top casing	EN-GJS-400-18-LT	
10.70	discharge casing	EN-GJS-400-18-LT	
10.80, 10.90, 11.40	intermediate piece	EN-GJS-400-18-LT	
21.00 - 21.03	shaft	X 20 Cr13	
23.10	impeller	EN-GJL 250	
23.50	vane wheel impeller	CuZn40Al2	PAEK
0241, 0243, 54.52	sleeve bearing	special carbon	
31.40 54.01	thrust bearing sleeve bearing	SiC	
34.60	stool	EN-GJL 250	
81.70	isolation can	Hastelloy C4	
84.71	inner magnet	X 6 Cr Ni Mo Ti 17 12 2 / Sm Co	
84.72	outer magnet	St 52-3 / Sm Co	

Dimensional drawing

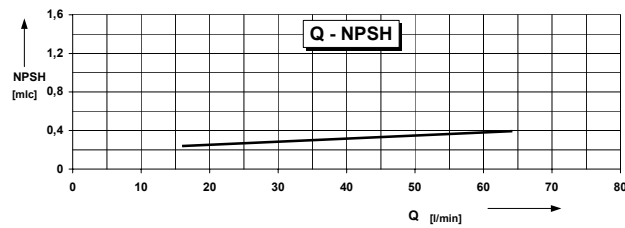
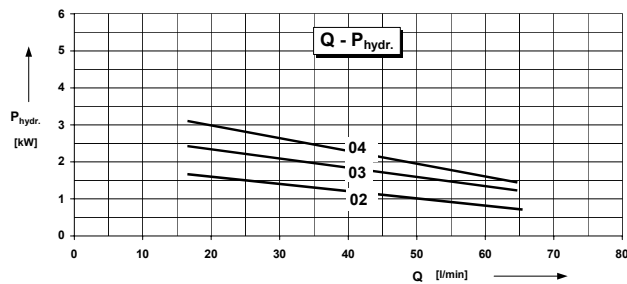
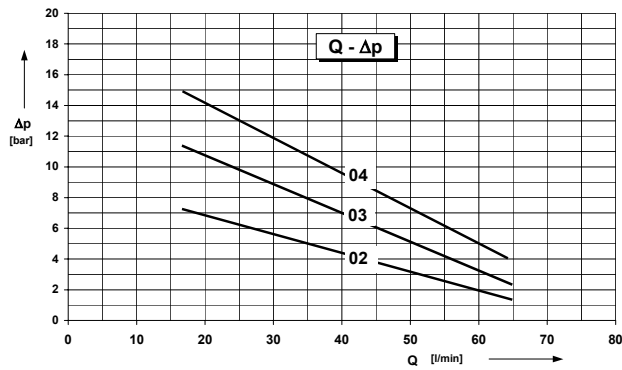

General : values are valid for LPG = 0.56 kg/l

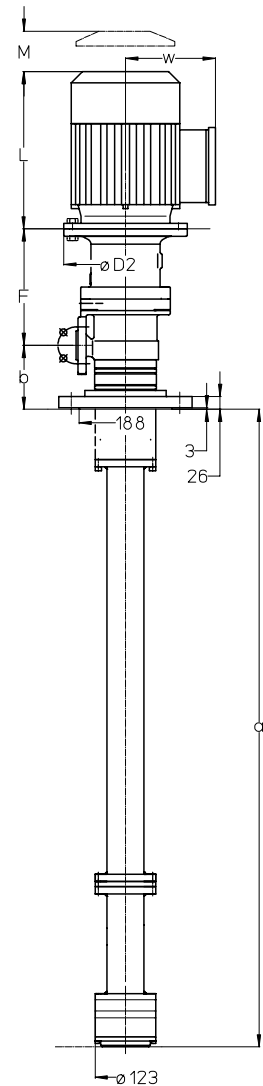
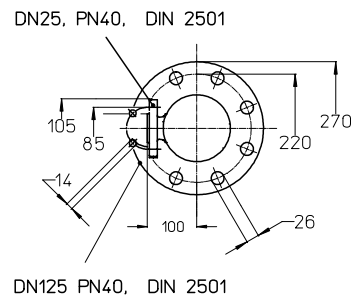

Dimensions in mm

Motor	EEXe / EEXd	D ₂	F	W	L	M	No. Stages	b
100 L	3,0 / 2,5 kW	250	237	227	340	30	2002	126
112 M	4,0 / 3,3 kW	250	237	239	348	30	2003	126
132 M	5,5 / 4,6 kW	300	257	254	440	30	2004	160

a									
1303	1404	1504	1767	1867	1967	2067	2167	2267	
2367	2430	2530	2630	2730	2830	2930	3030		

Installation:

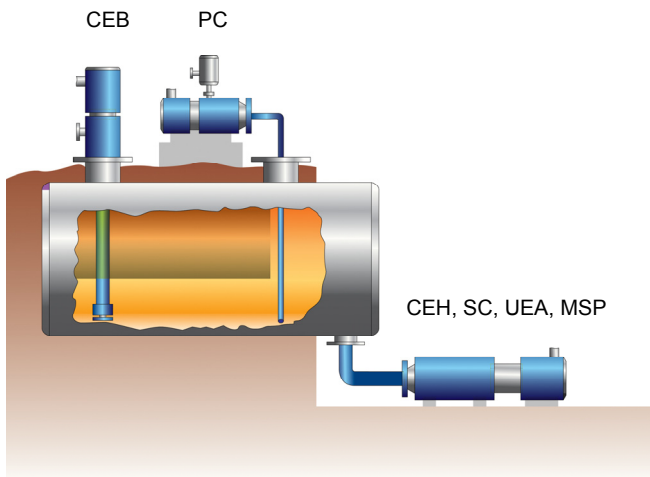
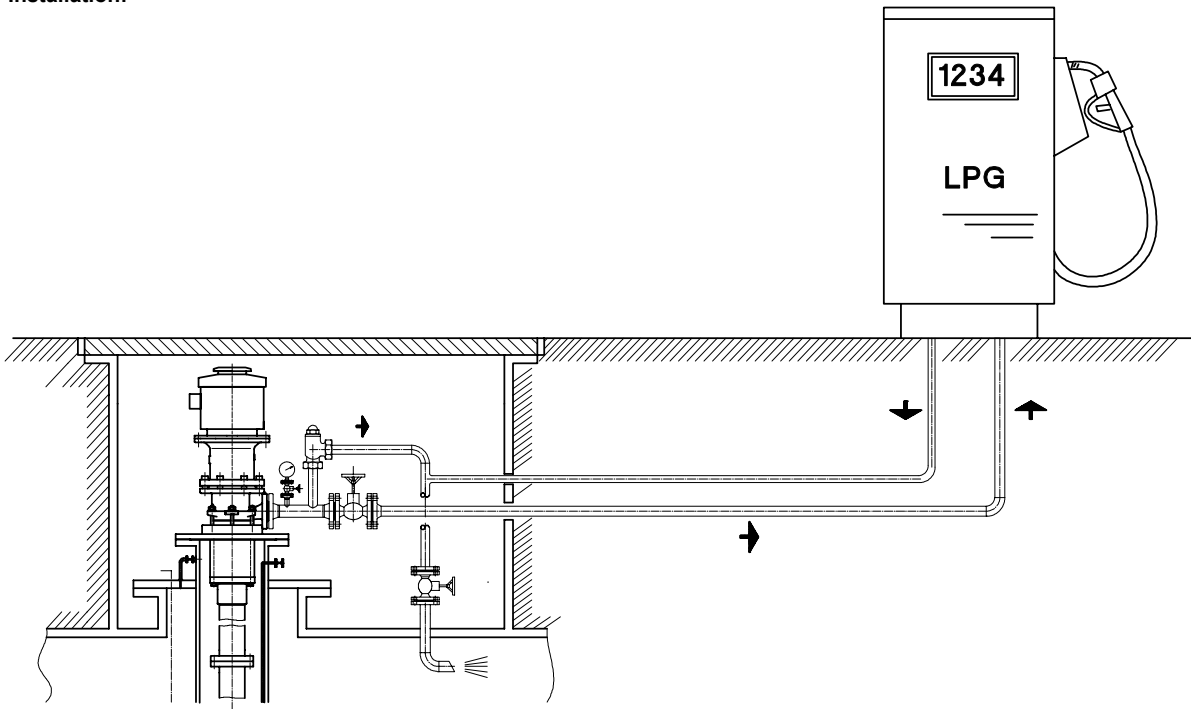

General comments:

Sterling-SIHI offers a variety of conventionally sealed and seal-less pumps for pumping up to 220m³/hr LPG from both underground and above-ground vessels. The product seeks to cover the three main concepts of: Flooded suction, for above ground tanks; Priming, for below ground; and Submerged, for above and below ground.

For elevated flow rates delivery pressures, again with very favourable NPSH conditions, Sterling SIHI offer an additional range of vertical tank pumps. This is the **CEB 3101 6104 or ZEB 5000 – 6500**. Both are available with magnetic coupling

For general industrial applications involving extremely poor suction conditions, or when pumping liquids/gasses at their boiling point, please consider the **CEH** and **SC 2000** side channel pumps. This is an end-suction construction that is also available with magnetic drive. Furthermore, when installed with the Sterling-SIHI **PC** plant, it can be mounted on top of the LPG storage tank. For higher flow rates involving unfavourable suction conditions, Sterling-SIHI can supply the **UEA, MSP** units also with magnetic coupling.