

Liquid ring vacuum pumps



LEH 2200, LEH 3000

Pressure range: 33 to 1013 mbar
Suction volume flow: 730 to 3550 m³/h

CONSTRUCTION TYPE

SIHI liquid ring vacuum pumps are displacement pumps of uncomplicated and robust construction with the following particular features:

- non-polluting due to nearly isothermal compression
- oil-free, as no lubrication in the working chamber
- handling of nearly all gases and vapours
- small quantities of entrained liquid can be handled
- easy maintenance and reliable operation
- low noise and nearly free from vibration
- wide choice of material, therefore applicable nearly everywhere
- Internal service liquid return; adjustable from the outside
- protection against cavitation as standard
- incorporated dirt drain
- incorporated central drain
- no metallic contact of the rotating parts

The SIHI liquid ring vacuum pumps LEH are single-stage ones.

APPLICATION

Handling and exhausting of dry and humid gases; entrained liquid can be handled during normal duty. The pumps are applied in all fields where a pressure of 33 to 900 mbar must be created by robust vacuum pumps.

Fields of application are for example:

- chemistry and pharmacy for distilling and degassing,
- electric industry for impregnation and drying
- plastics industry for degassing etc.



NOTE

During operation the pump must continuously be supplied with service liquid, normally water, in order to eliminate the heat resulting from the gas compression and to replenish the liquid ring, because part of the liquid is leaving the pump together with the gas. This liquid can be separated from the gas in a liquid separator (see catalogue part accessories).

It is possible to reuse the service liquid. The pumps are equipped with a device by which the contaminated service liquid can continuously be drained during operation (dirt drain), if necessary.

The direction of rotation is clockwise, when looking from the drive on the pump.

GENERAL TECHNICAL DATA

Pump type	unit	LEH 2200	LEH 3000
Speed	50 Hz 60 Hz		735 880
Max. compression over pressure	bar		1,5
Max. admissible pressure difference	bar		1,5
Hydraulic test (over pressure)	bar		3
Moment of inertial of the rotating pump parts and of the water filling	kg · m ²	8,7	10,8
Sound pressure level at a suction pressure of 80 mbar	dB (A)		80
Min. pulley diameter permissible in case of V-belt drive	mm	355	500
Max. gas temperature	dry °C saturated °C		160 80
Service liquid			
max. admissible temperature	°C		60
max. viscosity	mm ² /s		90
max. density	kg/m ³		1200
volume up to shaft level	liter	50	65
Max. flow resistance of the heat exchanger	bar		0,2

The combination of several limiting values is not admissible.

Material design

Item	COMPONENTS	MATERIAL DESIGN	
		0B	4B
10.60, 10.70	Casing	0.6025	1.4408
10.90	Central body	1.0038	1.4571
13.70, 13.71	Guide disk	0.6025	1.4408
21.00	Shaft	1.0503	
23.50	Vane wheel impeller	1.0553	1.4571
46.10	Gland packing	Soft packing	
52.40	Shaft sleeve	1.4027.05	1.4581

Sectional drawing LEH 2200, LEH 3000

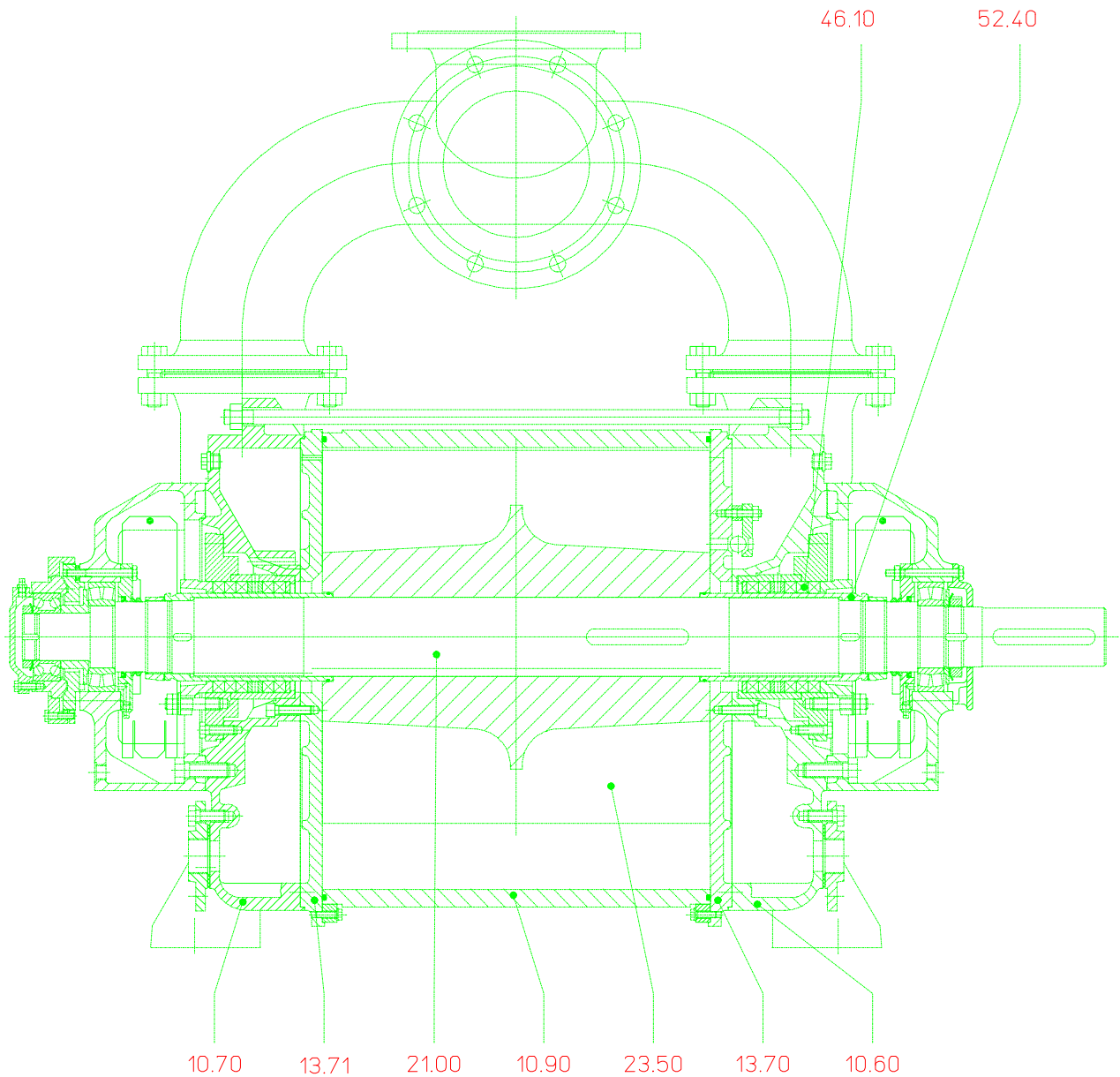

Suction volume flow and power absorption LEH 3000

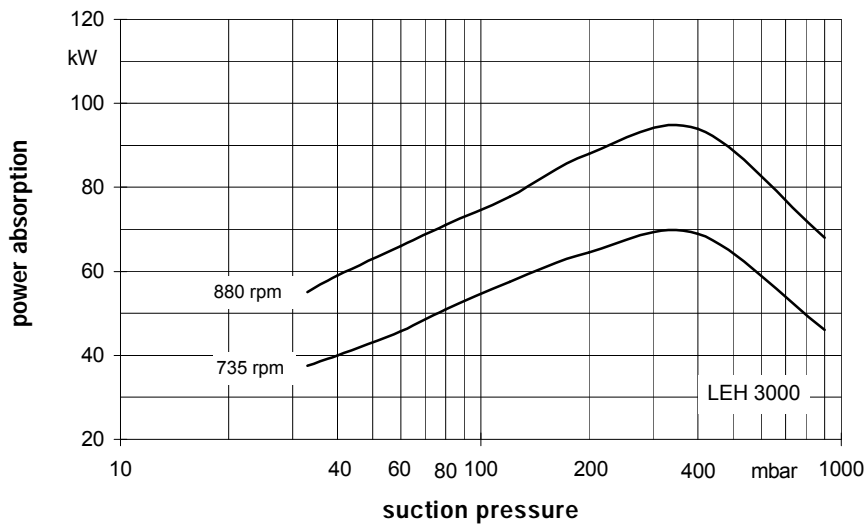
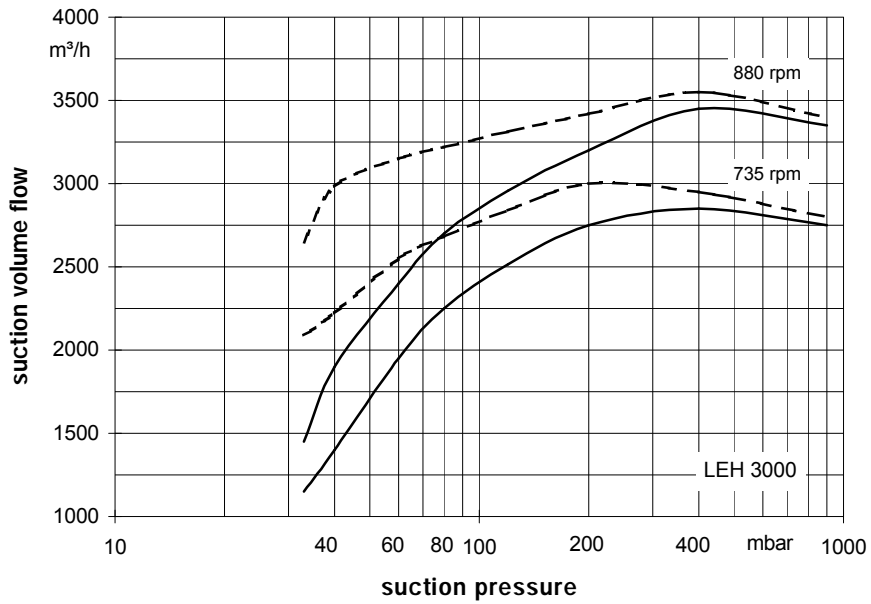

The operating data are applicable under the following conditions:

- pumping medium:
 - dry air: 20°C —————
 - water vapour saturated air: 20°C - - - - -
- service liquid:
 - water: 15°C

Compression pressure 1013 mbar (atmospheric pressure)

The suction volume flow is applied to the suction pressure

Tolerance of the operating data 10% and of the power absorption 5%

Max. fresh water need with lowest suction pressure

Dimension table LEH 2200, LEH 3000

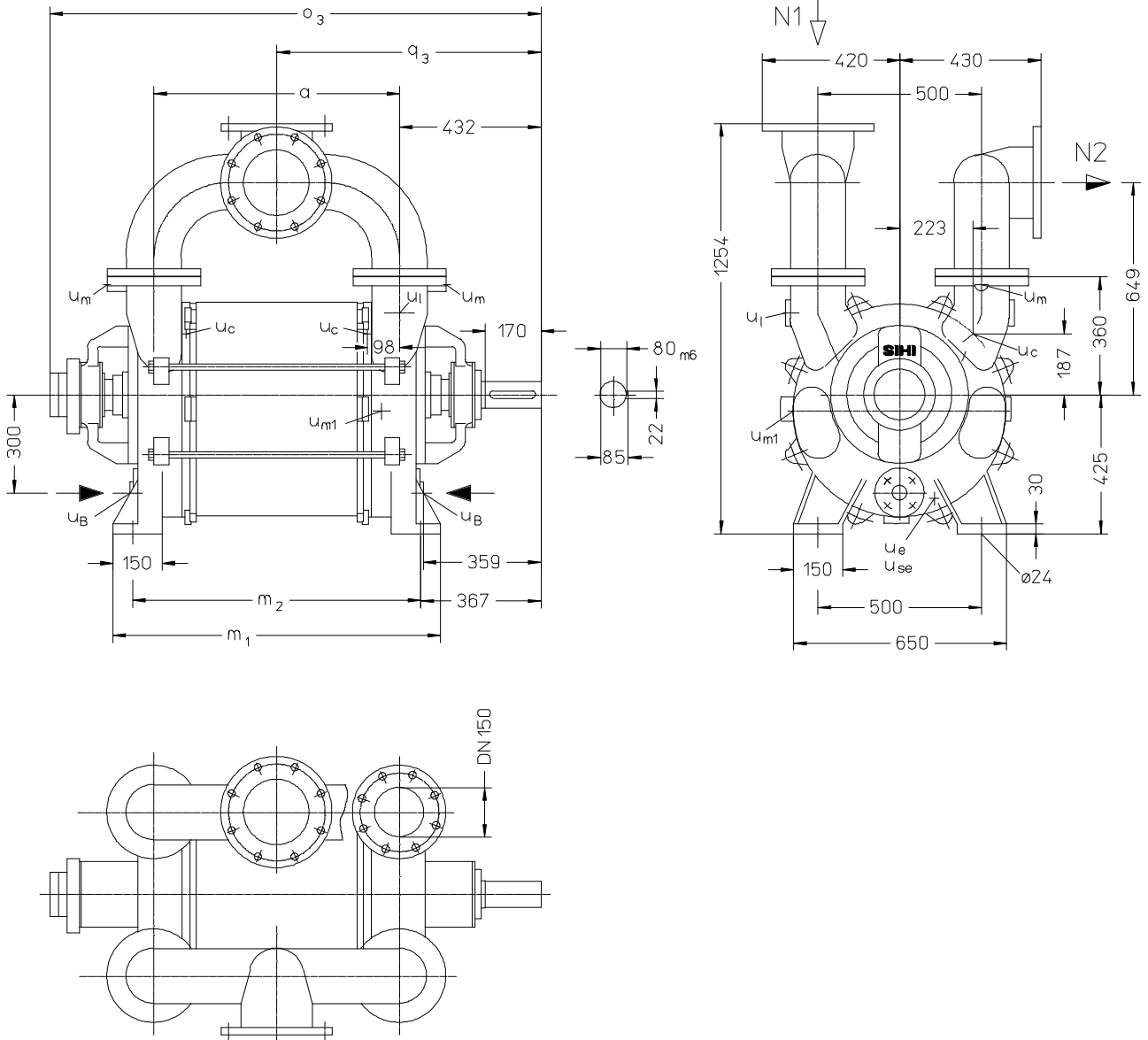

- N 1 = gas inlet DN 200
- N 2 = gas outlet DN 200
- u_B = connection for service liquid G 1½
- u_c = connection for protection against cavitation G ¼
- u_e = drain connection G ½
- u_l = connection for vent cock G ½
- u_m = connection for pressure gauge G ½
- u_{m1} = connection for drain valve G ½
- u_{se} = connection for dirt drain G ½

	a	m ₁	m ₂	o ₃	q ₃	weight app. kg
LEH 2200	630	880	760	1380	747	1025
LEH 3000	750	1000	880	1500	807	1100

flange connections to DIN 2501 PN 10		
DN	150	200
k	240	295
D	285	340
number x d ₂	8 x 22	8 x 23

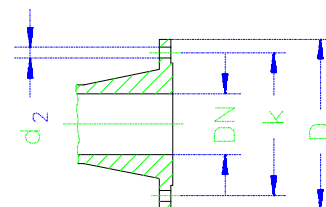

Arrangement drawing LEH 2200, LEH 3000 with overhead liquid separator

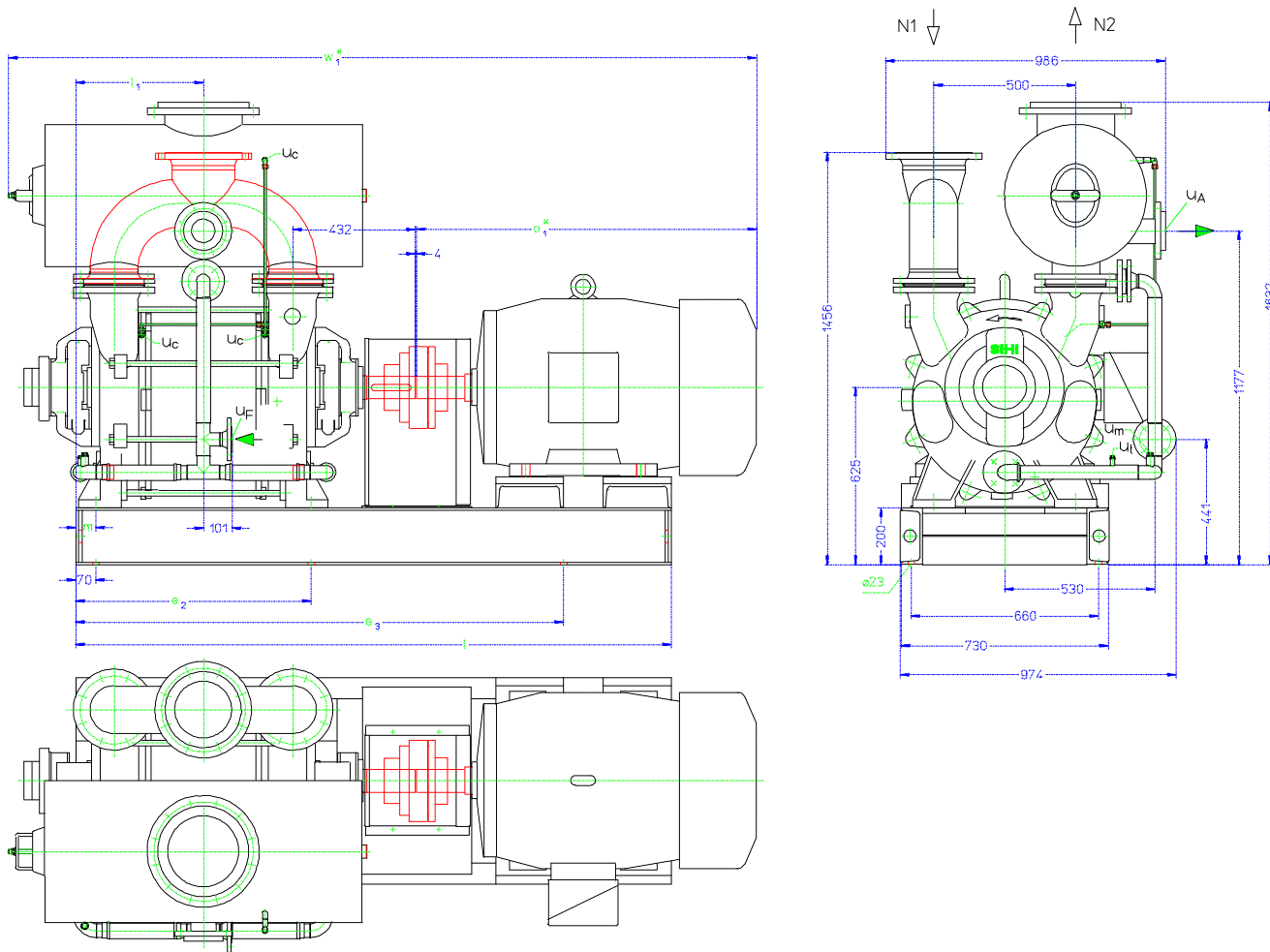

N 1 = gas inlet DN 200

N 2 = gas outlet DN 250

UA = connection for liquid drain DN 80

UF = connection for fresh liquid DN 40

Uc = connection for protection against cavitation G ¼

Um = connection for pressure gauge G ½

Ut = connection for thermometer G ¼

	electric motor 50 Hz			e ₂	e ₃	l	l ₁	m	o ₁ *	w ₁ *	weight app. kg
	size	kW									
LEH 2200	315 S	55	-	830	1720	2100	450	70	1200	2638	2320
	315 M	-	68								2689
LEH 3000	315 M	75	-	950	1830	2250	510	70	1251	2809	2500
	315 M	-	76								2570

flange connections to DIN 2501 PN 10				
DN	40	80	200	250
k	110	160	295	350
D	150	200	340	395
number x d ₂	4 x 18	8 x 18	8 x 22	12 x 22

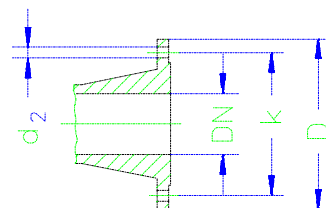

* dimensions dependent on the motor make

Fresh water requirements in [m³/h] dependent on suction pressure, speed, mode of operation and difference in temperature

suction pressure [mbar]		33				120				200				400			
pump	speed [rpm]	KB			FB	KB			FB	KB			FB	KB			FB
		difference in temperature [°C]				difference in temperature [°C]				difference in temperature [°C]				difference in temperature [°C]			
		10	5	2		10	5	2		10	5	2		10	5	2	
LEH 2200	735	2,3	4,1	7,8	18,6	3,1	5,1	8,4	14,7	3,2	5,2	8,1	13,2	3,2	4,9	7,3	10,8
	880	3,1	5,4	9,4		3,8	6,1	9,4		3,9	6,1	9,0		3,8	5,6	7,9	
LEH 3000	735	2,7	4,8	8,6		3,7	5,9	9,2		3,9	6,0	8,9		3,8	5,7	7,9	
	880	3,8	6,3	10,4		4,6	7,0	10,2		4,8	7,0	9,8		4,6	6,5	8,5	

FB = fresh liquid service

KB = combined liquid service with service water 10 °C, 5 °C, 2 °C warmer than the fresh water.

Data regarding the pump size - order notes

series + size	hydraulics + bearings	shaft sealing	material design	casing seal
	<ul style="list-style-type: none"> A• hydraulic A •B two grease lubricated antifriction bearings 	041 double gland packing	0B main parts of GG without non-ferrous metal 4B main parts of Cr Ni Mo cast steel	0 liquid seal
LEH 2200 3000	AB	041	0B, 4B	0

Design - Motor selection table

	designation	electric motor 50 Hz					
		motor enclosure IP 55			motor enclosure EEx e II T3		
pump with free shaft end	01	kW	size	designation	kW	size	designation
pump with coupling, pre-drilled at motor side	04						
as above, but with motor, for example		55	315 S	ED	68	315 MB	FM
75 kW three-phase motor	e.g. FD	75	315 M	FD	76	315 MC	GM
(50 Hz, 400 VΔ) at 735 rpm							

Example for ordering:

The construction size LEH 3000 AB 041 0B 0 with 75 kW three-phase ac motor (50 Hz, 400 VΔ) 735 rpm has the complete order number:

LEH- 3000 AB 041 0B 0 FD

If motors with other voltage or frequency are required a special information should be given.

On delivery the point (•) in the fourth place of the type code is replaced by a letter in the factory.

Accessories

Recommended accessories		LEH 2200	LEH 3000
Overhead liquid separator	type	XBa 10045	
material design	weight	150 kg	
130 / galvanized	SIHI part No.	35 009 513	XBa 10044
172 / 1.4571		35 009 514	155 kg
service liquid line			35 009 516
material design	SIHI part No.	35 006 069	35 009 517
072 / St 37-0		35 006 070	
172 / 1.4571			35 006 062
cavitation protection line			35 006 063
material design	SIHI part No.	20 037 202	20 037 204
072 / St 37-0		20 037 203	20 037 205
172 / 1.4571			
Upright liquid separator	type	XBp 5016	
material design	weight	153 kg	
130 / galvanized	SIHI part No.	35 006 074	
172 / 1.4571		35 006 075	
service liquid line			
material design	SIHI part No.	35 006 067	35 006 071
072 / St 37-0		35 006 068	35 006 072
172 / 1.4571			
cavitation protection line			
material design	SIHI part No.	20 042 995	20 042 993
072 / St 37-0		20 042 996	20 042 994
172 / 1.4571			
SIHI-gas ejector		on request	
Non-return valve		on request	
Motor in case of standard design			
IP 55	size	315 S	315 M
	power	55 kW	75 kW
	weight	780 kg	875 kg
EEx e II T3	size	315 M	315 M
	power	68 kW	76 kW
	weight	875 kg	940 kg
Coupling			
for motor IP 55	type / weight	A 225 / 27 kg	
pump side	SIHI part No.	43 031 212	
motor side		43 029 025	
for motor EEx e II T3	type / weight	ADS 245 / 32 kg	
pump side	SIHI part No.	43 040 601	
motor side		43 029 321	
contact safety device			
material design	SIHI part No.	35 004 808	
076 / steel		35 004 809	
345 / 2.0321			
base frame			
for motor IP 55	SIHI part No.	35 005 915	35 006 060
081 / USt 37-1	weight	262 kg	269 kg
for motor EEx e II T3	SIHI part No.		
081 / USt 37-1	weight		
		35 006 060	
		269 kg	

Any changes in the interest of the technical development are reserved.

Sterling SIHI GmbH

Lindenstraße 170 , D-25524 Itzehoe, Germany , Telephone +49 (0) 48 21 / 7 71-01 , Fax +49 (0) 48 21 / 7 71-274