

Liquid ring vacuum pumps

two stage

LPH 10534



Pressure range: 33 to 1013 mbar
suction volume flow: 3300 to 7400 m³/h

CONSTRUCTION TYPE

Sterling SIHI liquid ring vacuum pumps are displacement pumps of uncomplicated and robust construction with the following particular features:

- handling of nearly all gases and vapours
- non polluting due to a nearly isothermal compression
- oil-free, as no lubrication in the working chamber
- small quantities of entrained liquid can be handled
- easy maintenance and reliable operation
- low noise and nearly free from vibration
- wide choice of material, therefore applicable nearly anywhere
- protection against cavitation as standard
- incorporated dirt drain
- no metallic contact of the rotating parts

The Sterling SIHI liquid ring vacuum pump LPH 10534 is a two stage pump.

APPLICATION

Handling and exhausting of dry and humid gases; entrained liquid can be handled during normal duty. The pumps are applied in all fields where a pressure of 33...900 mbar must be created by robust vacuum pumps.

Fields of application are for example:

- chemistry and pharmacy for distilling and degassing,
- electric industry for impregnation and drying
- plastics industry for degassing etc..

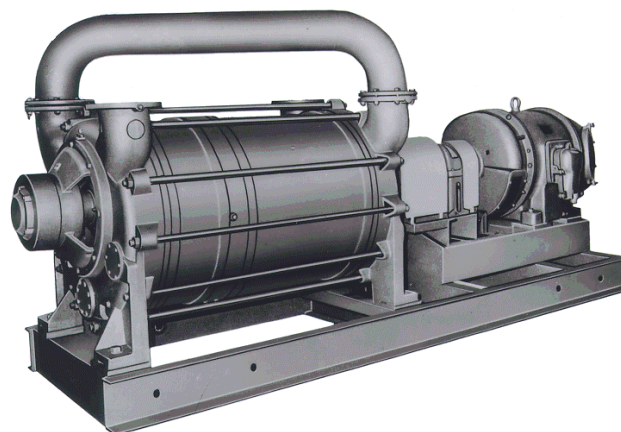

NOTE

During operation the pump must continuously be supplied with service liquid, normally water, in order to eliminate the heat resulting from the gas compression and to replenish the liquid ring, because part of the liquid is leaving the pump together with the gas. This liquid can be separated from the gas in a liquid separator (see catalogue part accessories).

It is possible to reuse the service liquid. The pumps are with a device by which the contaminated service liquid can be drained during operating (dirt drain), if necessary.

The direction of the rotation is clockwise, when looking from the drive on the pump.

GENERAL TECHNICAL DATA

Pump type	unit	LPH 10534		
Speed	rpm	400	490 ¹⁾	590
¹⁾ normal speed				
Max. compression over pressure	bar		1,5	
Max. admissible difference	bar		1,2	
Hydraulic test (over pressure)	bar		3	
Moment of inertial of the rotating pump parts and of the water filling	kg · m ²		88	
Sound pressure level at a suction of 80 mbar	dB (A)	88	89	90
Min. Pulley diameter permissible in case of V-belt drive	mm		1000	
max. gas temperature	°C		160	
	dry			
	saturated		80	
Service liquid				
max. admissible temperature	°C		60	
max. viscosity	mm ² /s		90	
max. density	kg/m ³		1200	
volume up to shaft level	liter		400	
Max. flow resistance of the heat exchanger	bar		0,2	

The combination of several limiting values is not admissible.

Material Design

Item	COMPONENTS	MATERIAL DESIGN
		02
0001, 0002	Casing	0.6025
0010, 0011, 0012, 0013	Guide disk	0.6025
0030, 0031	Vane wheel impeller	1.0570
0035, 0036	Central body	1.0038
0200	Shaft	1.0503
0270, 0271	Shaft sleeve	1.4027.05
0400	Gland packing	GORE

Sectional drawing LPH 10534

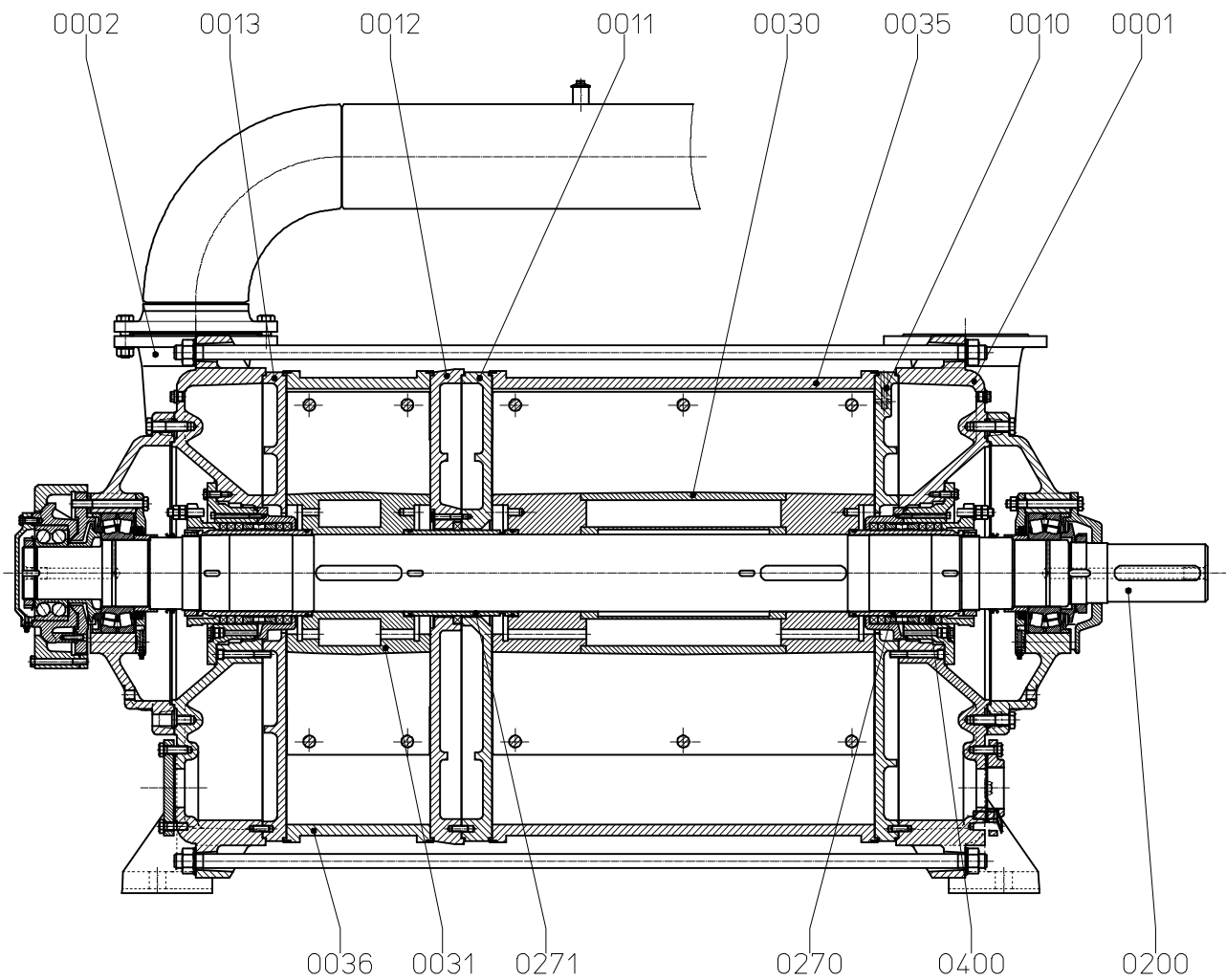

Suction volume flow and power absorption LPH 10534

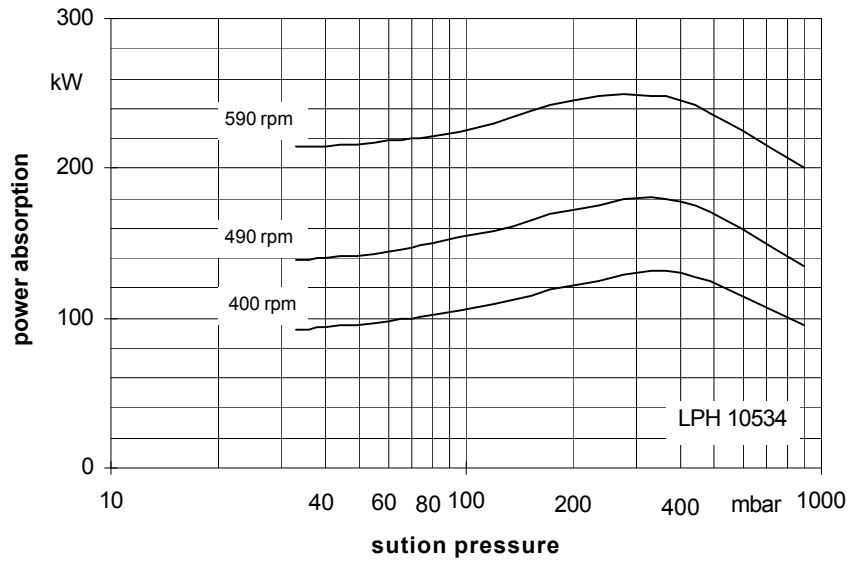
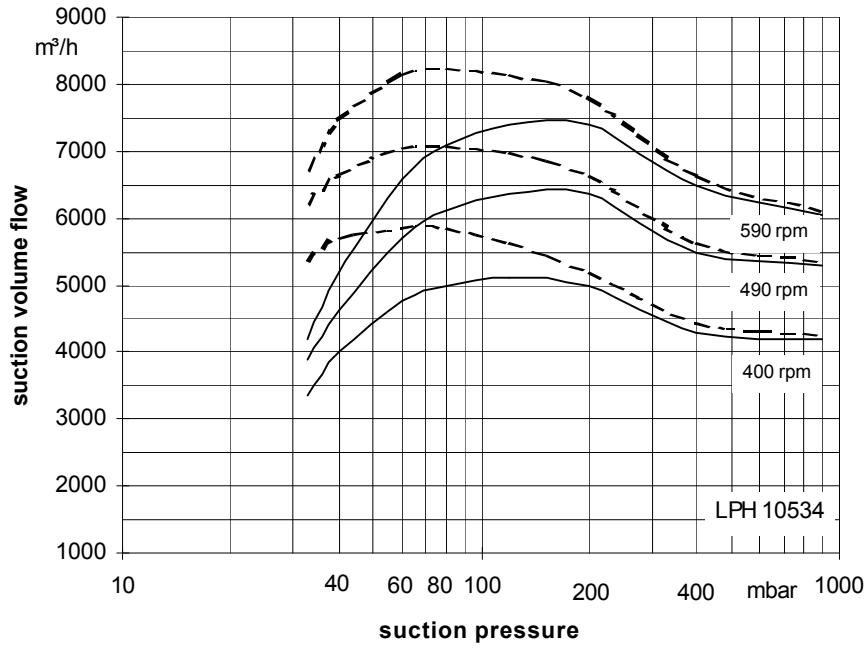

The operation data are applicable under the following conditions:

- pumping medium:
 - dry air: 20°C _____
 - water vapour saturated air: 20°C - - - - -
- service liquid:
 - water: 15°C _____

Compression pressure 1013 mbar (atmospheric pressure)
 The suction volume flow is applied to the suction pressure
 Tolerance of the operating data 10%
 Max. freshwater need with lowest suction pressure

Dimension table LPH 10534

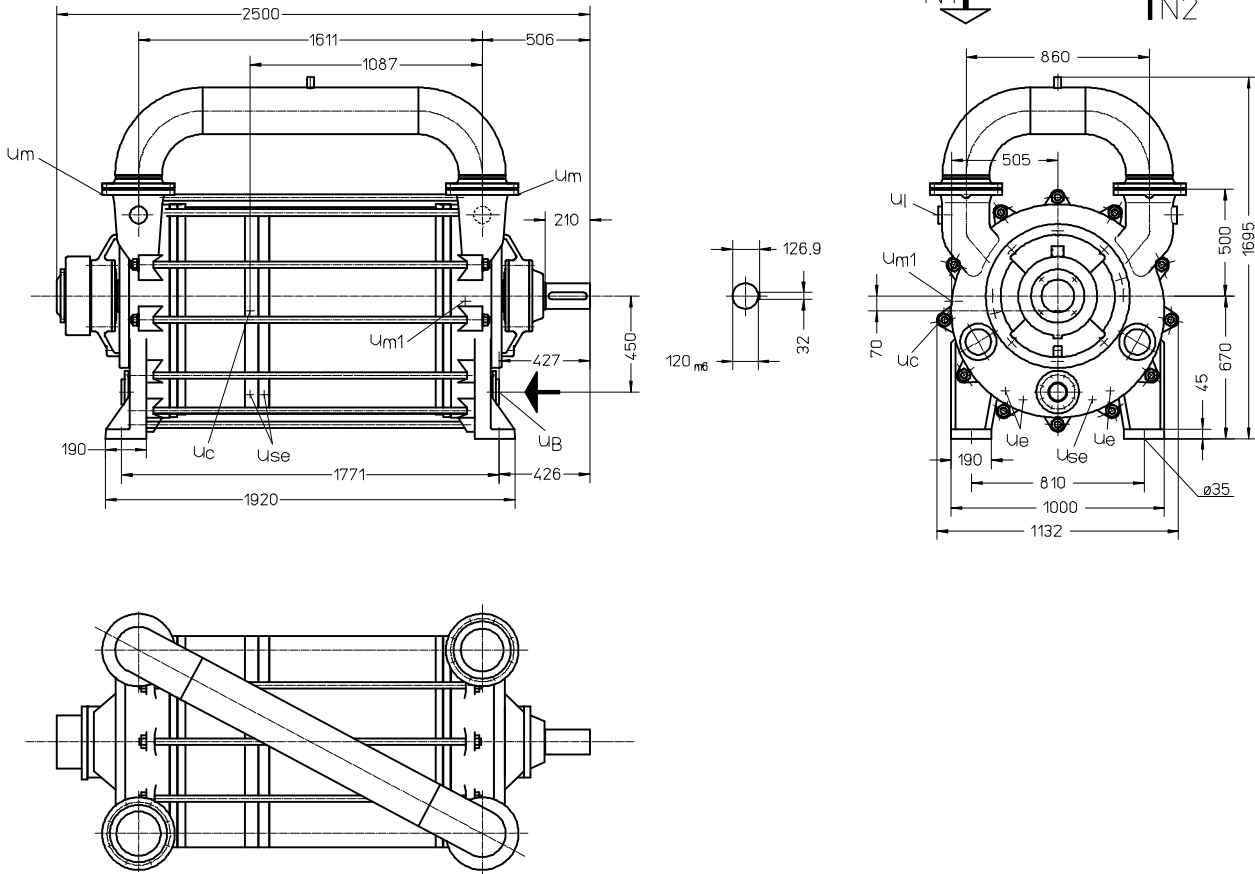

- N 1 = gas inlet DN 200
- N 2 = gas outlet DN 200
- u_B = connection for service liquid G 3
- u_c = connection for protection against cavitation G 3/4
- u_e = drained connection G 3/4
- u_l = connection for vent cock G 1 1/2
- u_m = connection for pressure gauge G 1/2
- u_{m1} = connection for drain valve G 3/4
- u_{se} = connection for dirt drain G 3/4

	weight abt. kg for material design	
	02	42
LPH 10534 BN	3850	4150

flange connections to DIN 2501 PN 10	
DN	200
k	295
D	340
number x d ₂	8 x 23

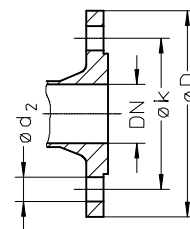

Fresh water requirements in [m³/h] dependent on suction pressure, speed, mode of operation and difference in temperature

suction pressure [mbar]		33				120				200				400							
pump type	speed [rpm]	KB				FB	KB				FB	KB				FB					
		difference in temperature [°C]					difference in temperature [°C]					difference in temperature [°C]									
		20	10	5	2		20	10	5	2		20	10	5	2		20	10	5	2	
LPH 10534	400		6,3	10,4	17,1	30	4,0	7,0	11,1	17,2	27	4,3	7,3	11,2	16,5	24	4,1	6,6	9,3	12,4	16
	490		8,5	13,3	20,0		5,4	9,0	13,5	19,3		5,7	9,2	13,3	18,1		5,2	7,8	10,5	13,2	
	590		11,4	16,6	22,6		7,2	11,4	16,0	21,2		7,3	11,2	15,3	19,5		6,3	9,1	11,6	13,9	

FB = fresh liquid service

KB = combined liquid service with service water 20°C, 10 °C, 5 °C, 2 °C warmer than the fresh water

Data regarding the pump size - order hints

series + size	bearings + direction of rotation	shaft sealing	material design	casing sealing
	<ul style="list-style-type: none"> • B two grease lubricated antifriction bearing • N one shaft end clockwise rotating 	041 double gland packing	02 main parts GG without non-ferrous metal	0 liquid seal
LPH 10534	BN	041	02	0

Upon request (dependent on the operating conditions) this vacuum pump is available as complete unit (e.g. pump, couplings, contact safety device and gear mounted on a base frame).

Design - Motor selection table

	designation	electric motor 50 Hz	
pump with free shaft end	01	motor protection IP 55	
pump with coupling, pre-drilled at motor side	04	kW	size
as above, but with gearing, motor and base frame	order	160	315L
	with text	200	315L
	in clear	250	315
		315	315

Motor: If motors with the other voltage, type of protection and frequency are required a special information should be given.

Accessories

Recommended accessories		LPH 10534			
Upright liquid separator		XBp 15112			
type		260 kg			
weight		35000601			
SIHI part No.		35000602			
material design	130 / galvanized 172 / 1.4571				
service liquid line					
material design		SIHI part No.			
072 / St 37-0 172 / 1.4571		20027255			
		on request			
discharge line (bend)					
material design		SIHI part No.			
072 / St 37-0 172 / 1.4571		20027265			
		35003239			
Motor in case of standard design		315L	315L	315	315
IP 55		size	power	weight	weight
		160 kW	200 kW	250 kW	300 kW
		1060 kg	1200 kg	1300 kg	1500 kg

Any changes in the interest of technical development are reserved.

Sterling SIHI GmbH

Lindenstraße 170, D-25524 Itzehoe, Germany, Telephone +49 (0)48 21 / 7 71 - 01, Fax +49 (0)48 21 / 7 71-274