

Liquid ring vacuum pumps

two stage



LPH 11535

Pressure range: 33 to 1013 mbar
Suction volume flow: 4900 to 10350 m³/h

CONSTRUCTION TYPE

Sterling SIHI liquid ring vacuum pumps are displacement pumps of uncomplicated and robust construction with the following particular features:

- handling of nearly all gases and vapours
- non polluting due to a nearly isothermal compression
- oil-free, as no lubrication in the working chamber
- small quantities of entrained liquid can be handled
- easy maintenance and reliable operation
- low noise and nearly free from vibration
- wide choice of material, therefore applicable nearly anywhere
- protection against cavitation as standard
- incorporated dirt drain
- no metallic contact of the rotating parts

The Sterling SIHI liquid ring vacuum pump LPH 11535 is a two stage pump.

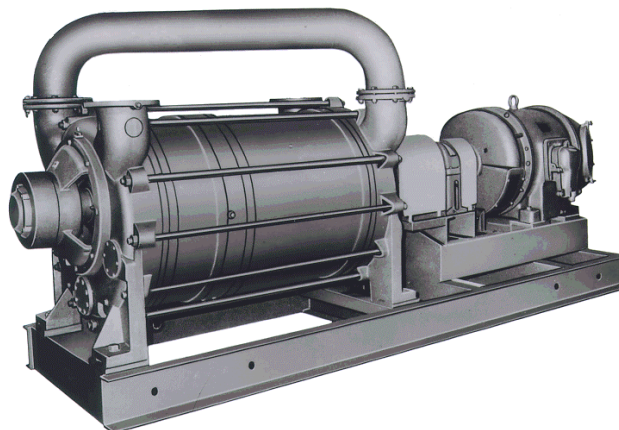

APPLICATION

Handling and exhausting of dry and humid gases; entrained liquid can be handled during normal duty. The pumps are applied in all fields where a pressure of 33...900 mbar must be created by robust vacuum pumps.

Fields of application are for example:

- chemistry and pharmacy for distilling and degassing,
- electric industry for impregnation and drying
- plastics industry for degassing etc.

NOTE

During operation the pump must continuously be supplied with service liquid, normally water, in order to eliminate the heat resulting from the gas compression and to replenish the liquid ring, because part of the liquid is leaving the pump together with the gas. This liquid can be separated from the gas in a liquid separator (see catalogue part accessories).

It is possible to reuse the service liquid. The pumps are with a device by which the contaminated service liquid can be drained during operating (dirt drain), if necessary.

The direction of the rotation is clockwise, when looking from the drive on the pump.

GENERAL TECHNICAL DATA

Pump type	unit	LPH 11535		
Speed				
¹⁾ normal speed	rpm	355	415 ¹⁾	470
Max. compression over pressure	bar		1,5	
Max. admissible difference	bar		1,2	
Hydraulic test (over pressure)	bar		3	
Moment of inertial of the rotating pump parts and of the water filling	kg · m ²		195	
Sound pressure level at a suction pressure of 80 mbar	dB (A)	89	90	91
Min. pulley diameter permissible in case of V-belt drive	mm		1250	
Max. gas temperature	°C		160	
	dry			
	saturated		80	
Service liquid				
max. admissible temperature	°C		60	
max. viscosity	mm ² /s		90	
max. density	kg/m ³		1200	
volume up to shaft level	liter		680	
Max. flow resistance of the heat exchanger	bar		0,2	

The combination of several limiting values is not admissible.

Material design

Item	COMPONENTS	MATERAIL DESIGN
		02
0001, 0002	Casing	0.6025
0010, 0011, 0012, 0013	Guide disk	0.6025
0030, 0031	Vane wheel impeller	1.0570
0035, 0036	Central body	1.0038
0200	Shaft	1.0503
0270, 0271	Shaft sleeve	1.4027.05
0400	Gland packing	GORE

Sectional drawing LPH 11535

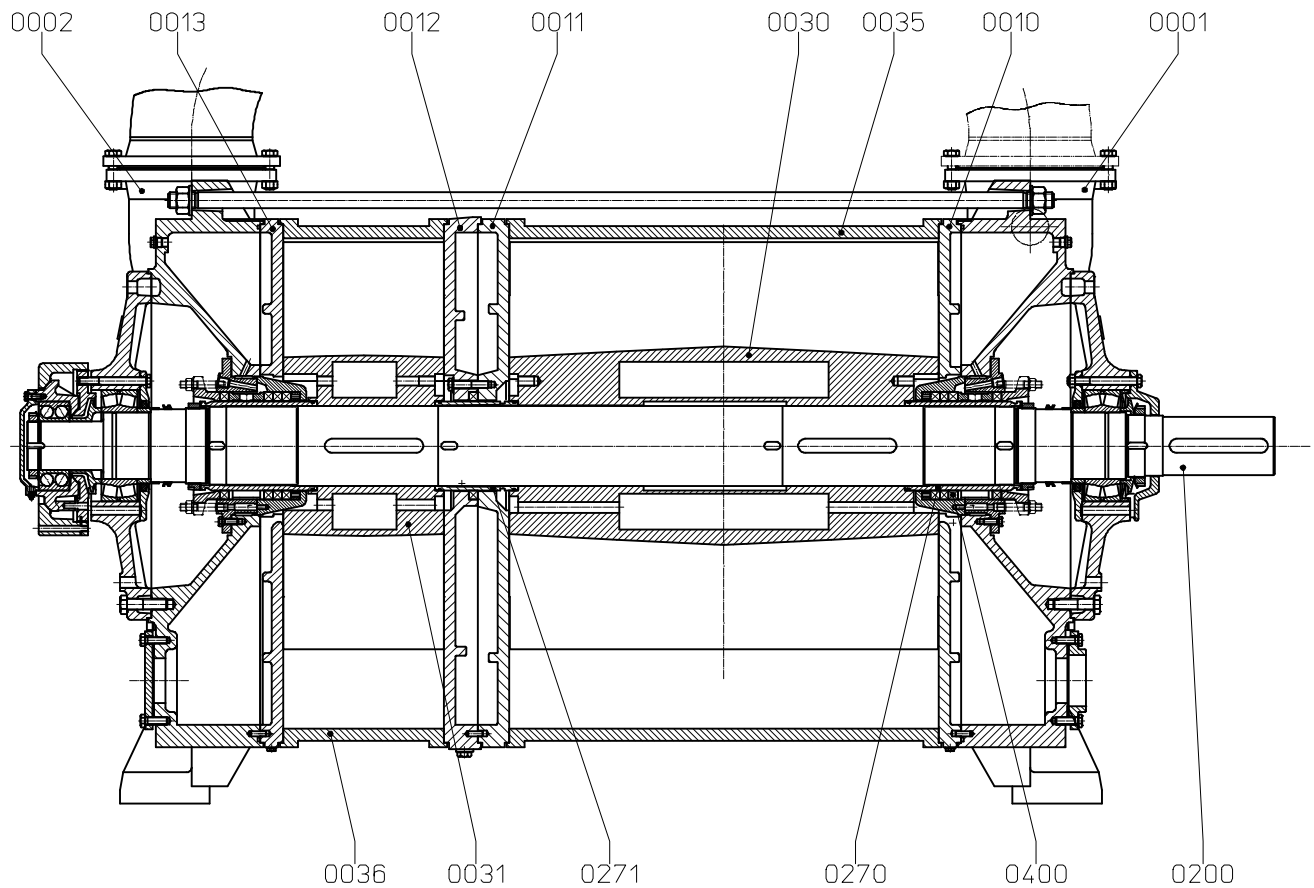

Suction volume flow and power absorption LPH 11535

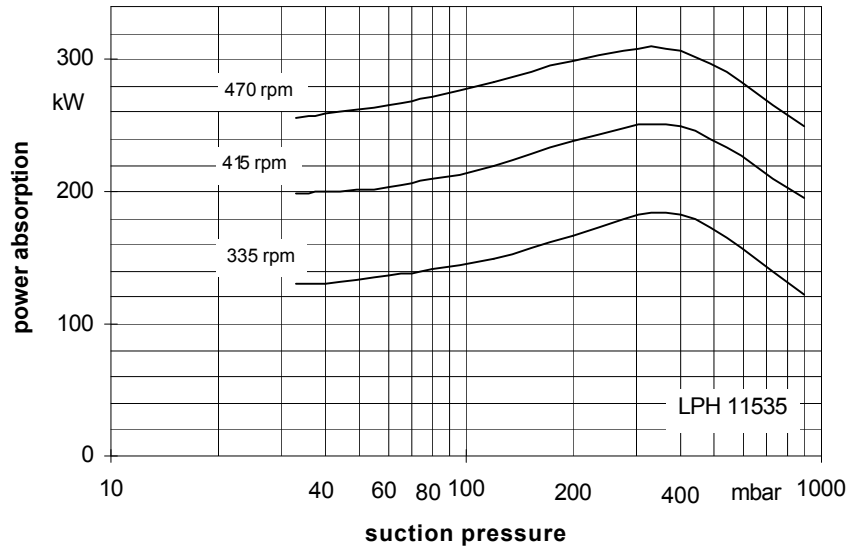
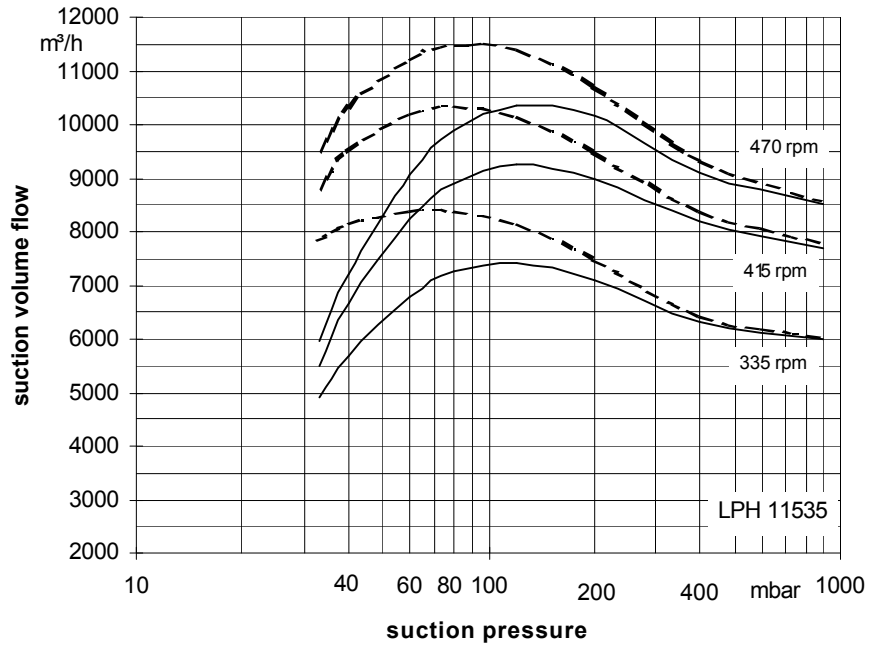

The operating data are applicable under the following conditions:

- pumping medium:
 - dry air: 20°C _____
 - water vapour saturated air: 20°C - - - - -
- service liquid:
 - water: 15°C

Compression pressure 1013 mbar (atmospheric pressure)

The suction volume flow is applied to the suction pressure

Tolerance of the operating data 10%

Max. fresh water need with lowest suction pressure

Dimension table LPH 11535

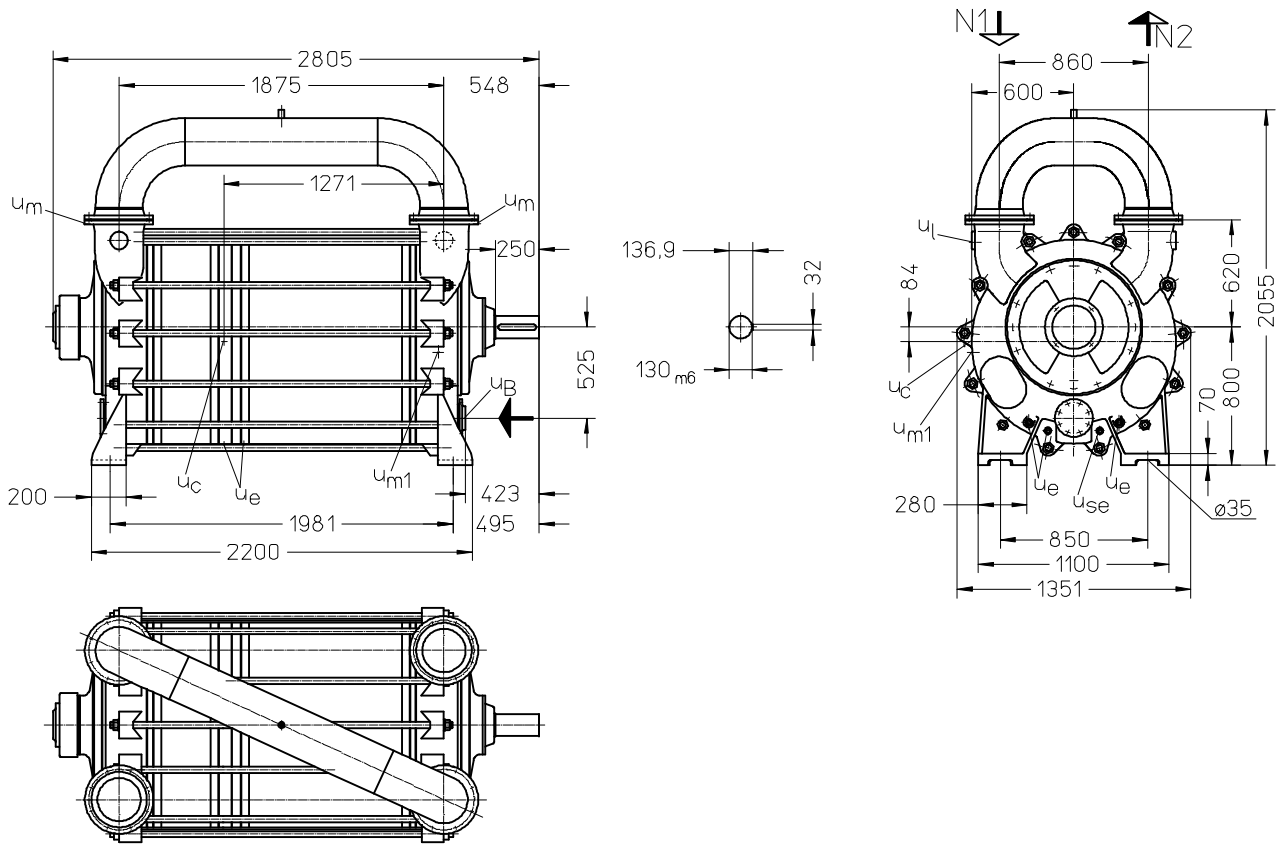

- N 1 = gas inlet DN 250
- N 2 = gas outlet DN 250
- u_B = connection for service liquid G 4
- u_c = connection for protection against cavitation G $\frac{3}{4}$
- u_e = drained connection G 1
- u_l = connection for vent cock G 1 $\frac{1}{2}$
- u_m = connection for pressure gauge G $\frac{1}{2}$
- u_{m1} = connection for drain valve G 1
- u_{se} = connection for dirt drain G 1

	weight abt. kg for material design 02
LPH 11535 BN	5800

flange connections to DIN 2501 PN 10	
DN	250
k	350
D	395
number x d_2	12 x 22

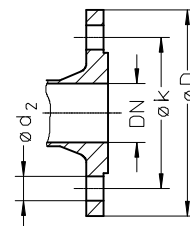

Fresh water requirements in [m³/h] dependent on suction pressure, speed, mode of operation and difference in temperature

suction pressure [mbar]		33				120				200				400							
pump	speed [rpm]	KB				FB	KB				FB	KB				FB					
		difference in temperature [°C]					difference in temperature [°C]					difference in temperature [°C]									
		20	10	5	2		20	10	5	2		20	10	5	2						
LPH 11535	335		8,7	14,2	23,0	39	5,5	9,6	15,3	23,8	38	5,9	9,9	15,1	22,1	32	5,5	8,6	11,8	15,3	19
	415		11,8	18,2	26,7		7,6	12,6	19,0	27,1		7,7	12,5	18,0	24,4		6,9	10,1	13,2	16,1	
	470		14,1	20,7	28,8		9,2	14,8	21,3	29,0		9,1	14,2	19,7	25,6		7,8	11,0	14,0	16,6	

FB = fresh liquid service

KB = combined liquid service with service water 20°C, 10 °C, 5 °C, 2 °C warmer than the fresh water.

Data regarding the pump size - order hints

series + size	bearings + direction of rotation	shaft sealing	material design	casing seal
	<ul style="list-style-type: none"> • B two grease lubricated antifriction bearing • N one shaft end clockwise rotating 	41 double gland packing	2 main parts GG without non-ferrous metal	0 liquid seal
LPH 11535	BN	041	02	0

Upon request (dependent on the operating conditions) this vacuum pump is available as complete unit (e.g. pump, couplings, contact safety device and gear mounted on a base frame).

Design - Motor selection table

	designation	electric motor 50 Hz	
pump with free shaft end	01	motor protection IP 55	
pump with coupling, pre-drilled at motor side	04	kW	size
as above, but with gearing, motor and base frame	order	200	315L
	with text	250	315
	in clear	315	315
		400	355

Motor: If motors with the other voltage, type of protection and frequency are required a special information should be given.

Accessories

Recommended accessories		LPH 11535				
Upright liquid separator		type	XBp 15112			
		weight	325 kg			
material design	130 / galvanized 172 / 1.4571	SIHI part No.	20000624 20000625			
service liquid line						
material design	072 / St 37-0 172 / 1.4571	SIHI part No.	20027262 on request			
discharge line (bend)						
material design	072 / St 37-0 172 / 1.4571	SIHI part No.	20027266 on request			
Motor in case of standard design		size	315L	315	315	355
IP 55		power	200 kW	250 kW	315 kW	400 kW
		weight	1200 kg	1300 kg	1500 kg	2000 kg

Any changes in the interest of the technical development are reserved.

Sterling SIHI GmbH

Lindenstraße 170, D-25524 Itzehoe, Germany, Telephone +49 (0)48 21 / 7 71 - 01, Fax +49 (0)48 21 / 7 71-274