

# Liquid ring vacuum pumps

two stage



## LPH 75320, LPH 75330, LPH 75340

**Pressure range:** 33 to 1013 mbar  
**suction volume flow:** 500 to 1700 m<sup>3</sup>/h

### CONSTRUCTION TYPE

Sterling SIHI liquid ring vacuum pumps are displacement pumps of uncomplicated and robust construction with the following particular features:

- handling of nearly all gasses and vapours
- non polluting due to a nearly isothermal compression
- oil-free, as no lubrication in the working chamber
- small quantities of entrained liquid can be handled
- easy maintenance and reliable operation
- low noise and nearly free from vibration
- wide choice of material, therefore applicable nearly anywhere
- protection against cavitation as standard
- incorporated dirt drain
- no metallic contact of the rotating parts

The Sterling SIHI liquid ring vacuum pumps LPH 75320, LPH 75330 and LPH 75340 are two stage pumps.

### APPLICATION

Handling and exhausting of dry and humid gases; entrained liquid can be handled during normal duty. The pumps are applied in all fields where a pressure of 33...900 mbar must be created by robust vacuum pumps.

Fields of application are for example:

- chemistry and pharmacy for distilling and degassing,
- electric industry for impregnation and drying
- plastics industry for degassing etc.



### NOTE

During the operation the pump must continuously be supplied with service liquid, normally water, in order to eliminate the heat resulting from the gas compression and to replenish the liquid ring, because part of the liquid is leaving the pump together with the gas. This liquid can be separated from the gas in a liquid separator (see catalogue part accessories).

It is possible to reuse the service liquid. The pumps are with a device by which the contaminated service liquid can be drained during operation (dirt drain), if necessary.

The direction of the rotation is clockwise, when looking from the drive on the pump.

### GENERAL TECHNICAL DATA

pump type	unit	LPH 75320	LPH 75330	LPH 75340
Speed <sup>1)</sup> normal speed	rpm	880 975 <sup>1)</sup> 1175	880 975 <sup>1)</sup> 1175	880 975 <sup>1)</sup> 1175
Max. compression over pressure	bar		1,5	
Max. admissible difference <sup>2)</sup> in case of belt drive	bar	1,8 1,8 1,4 <sup>2)</sup> 1,8	1,8 1,7 1,4 <sup>2)</sup> 1,6	1,7 1,6 1,4 <sup>2)</sup> 1,5
Hydraulic test (over pressure)	bar		3	
Moment of inertial of the rotating pump parts and of the water filling	kg · m <sup>2</sup>	1,57	2,23	2,65
Sound pressure level at a suction of 80 mbar	dB (A)	78 79 80	78 79 80	78 79 80
Min. pulley diameter permissible in case of V-belt drive	mm	315	355	355
Max. gas temperature	°C		200	
	dry		100	
	saturated			
Service liquid				
max. admissible temperature	°C		80	
max. viscosity	mm <sup>2</sup> /s		90	
max. density	kg/m <sup>3</sup>		1200	
volume up to shaft	liter	36	47	54
Max. flow resistance of the heat exchanger	bar		0,2	

The combination of several limiting values is not admissible.

## Material design

Item	COMPONENTS	MATERIAL DESIGN	
		02	42
0001, 0002	Casing	0.6025	1.4408
0010, 0011, 0012, 0013	Guide disk	0.6025	1.4408
0030, 0031	Vane wheel impeller	1.0570	1.4517
0035, 0036	Central body	1.0038	1.4408
0200	Shaft	1.0503	
0270, 0271	Shaft sleeve	1.4027.05	1.4581
0400	Gland packing	GORE	-
0500, 0600	Mechanical seal	Cr-steel / carbon / Perbunan	Cr Ni Mo-steel / carbon / Viton

## Sectional drawing LPH 75320, LPH 75330, LPH 75340

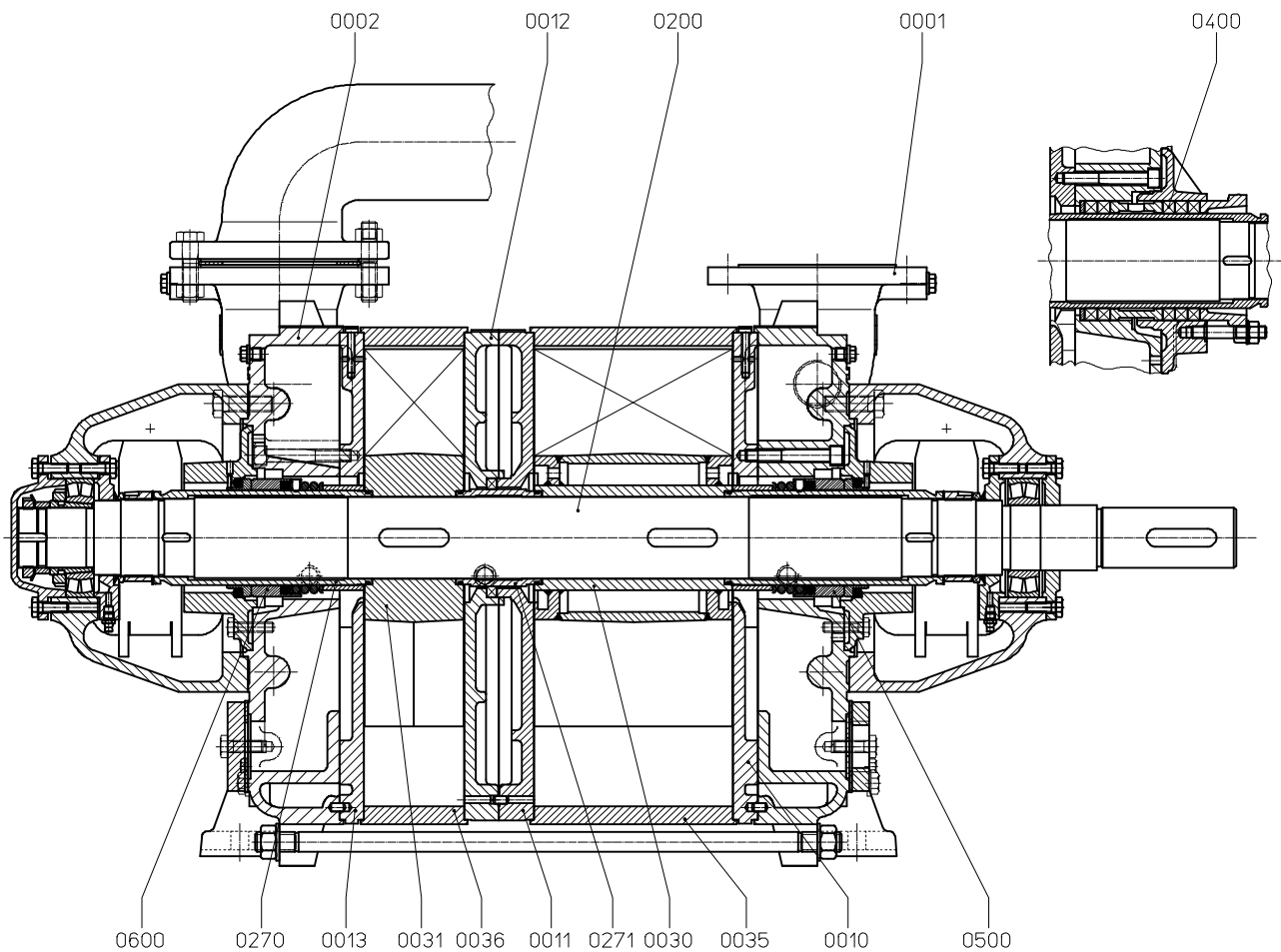

**Suction volume flow and power absorption LPH 75320**

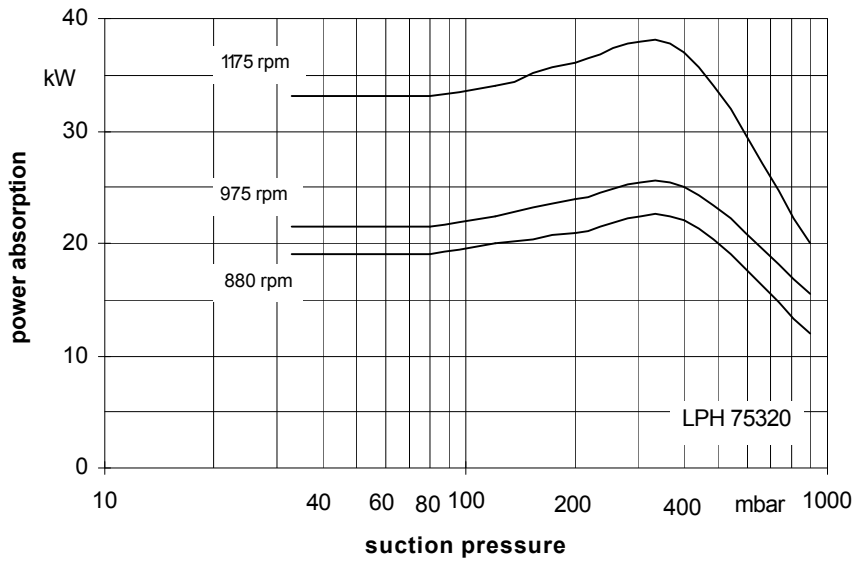
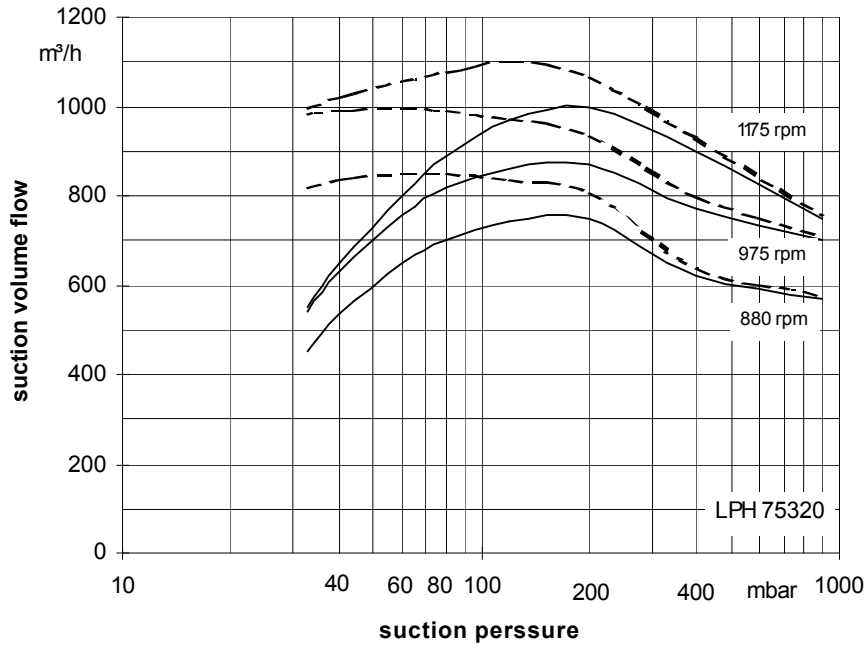

The operating data are applicable under the following conditions:

- pumping medium:
  - dry air: 20°C
  - water vapour saturated air: 20°C
- service liquid:
  - water: 15°C

Compression pressure 1013 mbar (atmospheric pressure)

The suction volume flow is applied to the suction pressure

Tolerance of the operating data 10%

Max. fresh water need with lowest suction pressure

## Suction volume flow and power absorption LPH 75330

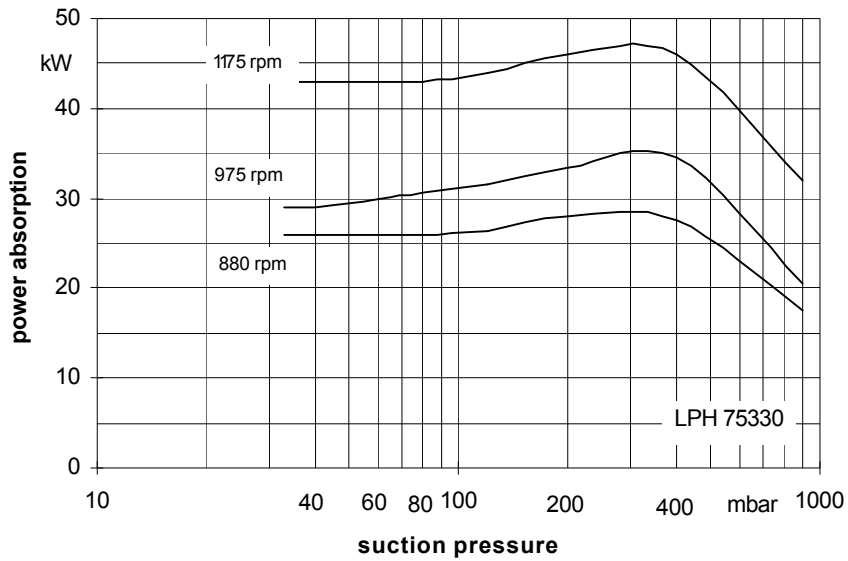
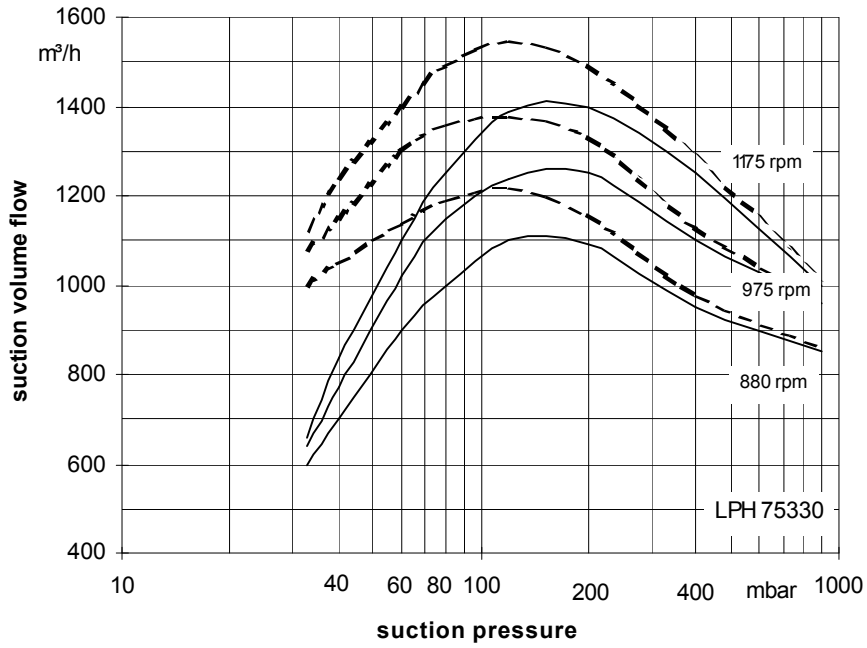

The operating data are applicable under the following conditions:

- pumping medium:
  - dry air: 20°C —————
  - water vapour saturated air: 20°C - - - - -
- service liquid:
  - water: 15°C

Compression pressure 1013 mbar (atmospheric pressure)

The suction volume flow is applied to the suction pressure

Tolerance of the operating data 10%

Max. fresh water need with lowest suction pressure

## Suction volume flow and power absorption LPH 75340

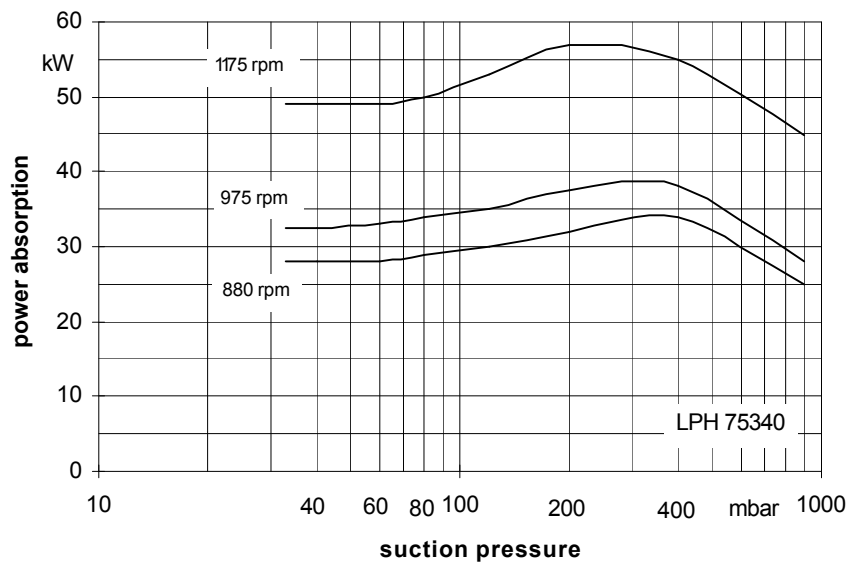
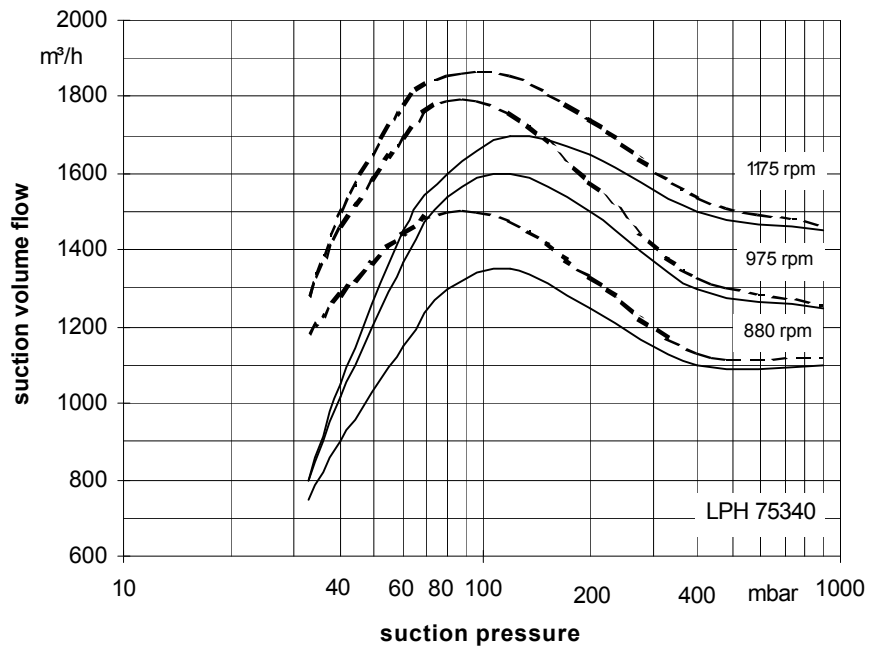

The operating data are applicable under the following conditions:

- pumping medium:
  - dry air: 20°C \_\_\_\_\_
  - water vapour saturated air: 20°C - - - - -
- service liquid:
  - water: 15°C

Compression pressure 1013 mbar (atmospheric pressure)

The suction volume flow is applied to the suction pressure

Tolerance of the operating data 10%

Max. fresh water need with lowest suction pressure

**Dimension table LPH 75320, LPH 75330, LPH 75340**

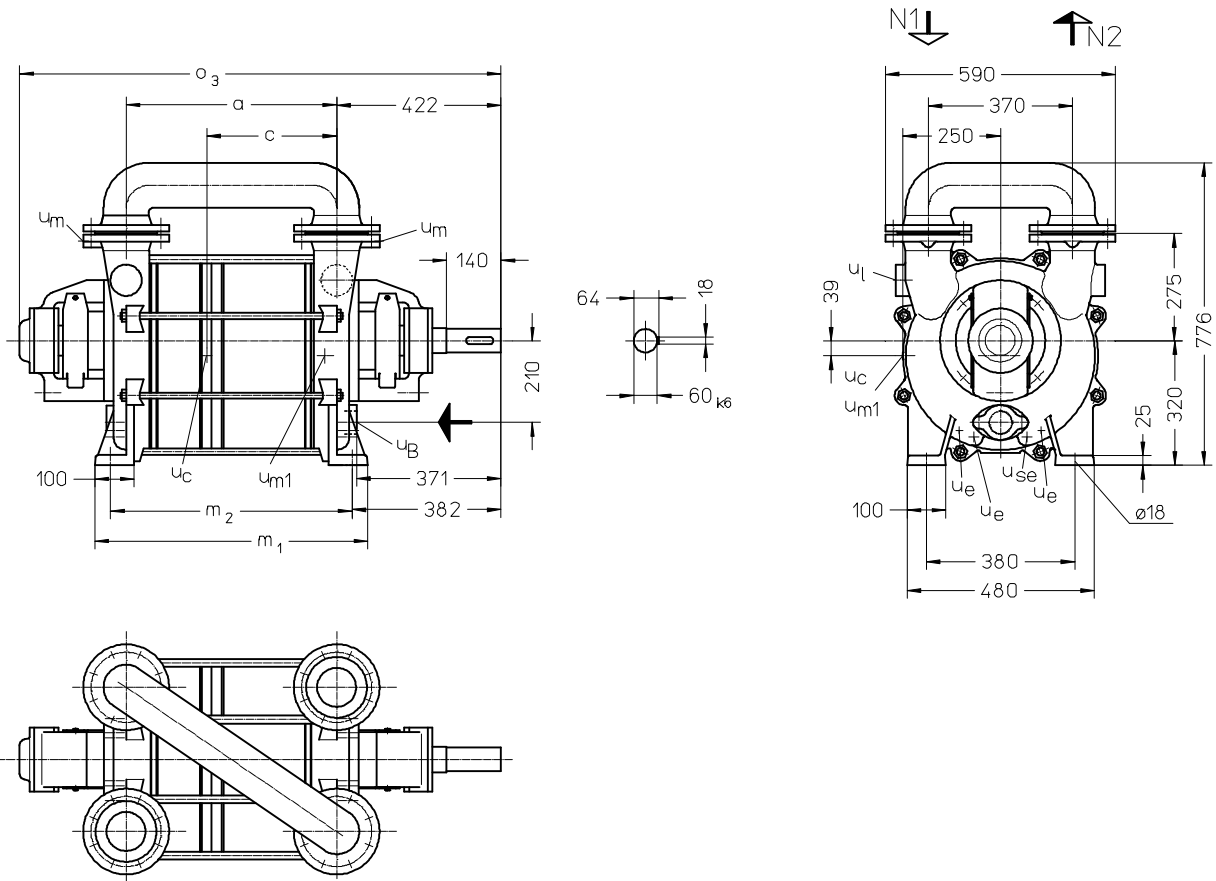

- N 1 = gas-inlet DN 100
- N 2 = gas-outlet DN 100
- u<sub>B</sub> = connection for service liquid G 2
- u<sub>c</sub> = connection for protection against cavitation G 3/8
- u<sub>e</sub> = drain connection G 1/4
- u<sub>l</sub> = connection for vent cock G 1 1/2
- u<sub>m</sub> = connection for pressure gauge G 3/8
- u<sub>m1</sub> = connection for drain valve G 1/2
- u<sub>se</sub> = connection for dirt drain G 1/2

	a	c	m <sub>1</sub>	m <sub>2</sub>	o <sub>3</sub>	weight abt. kg for material design	
						02	42
LPH 75320 BN	540	333	700	620	1235	450	485
LPH 75330 BN	690	434	850	770	1385	570	620
LPH 75340 BN	790	534	950	870	1485	640	690

flange connections to DIN 2501 PN 10	
DN	100
k	180
D	220
number x d <sub>2</sub>	8 x 18

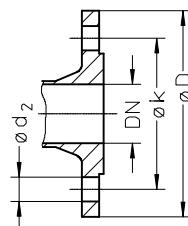

Arrangement drawing LPH 75320, LPH 75330, LPH 75340 with overhead liquid separator

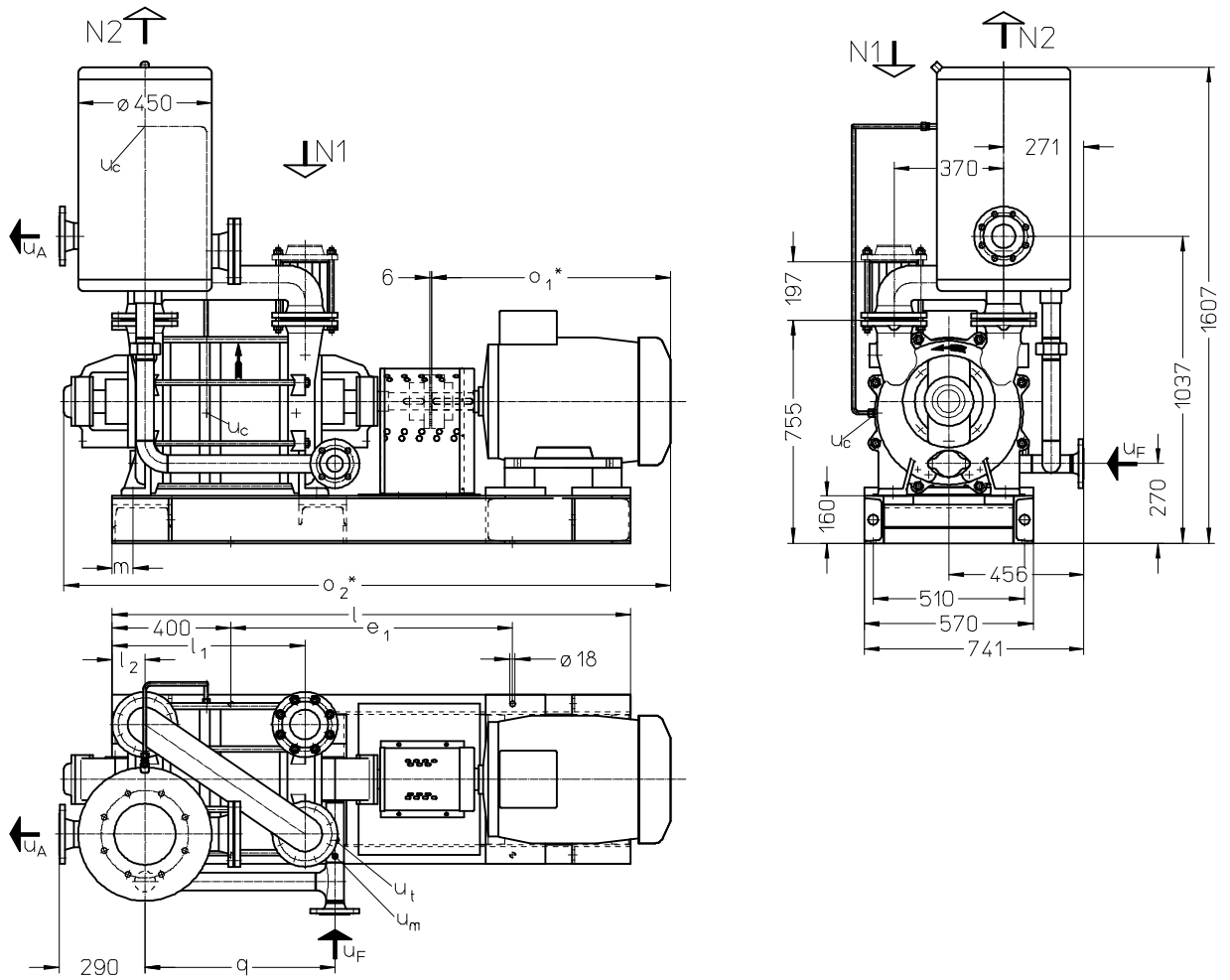

- N 1 = gas-inlet DN 100
- N 2 = gas-outlet DN 200
- u<sub>A</sub> = connection for liquid drain DN 80
- u<sub>c</sub> = connection for protection against cavitation G ¼
- u<sub>F</sub> = connection for fresh liquid DN 50
- u<sub>m</sub> = connection for pressure gauge G ¼
- u<sub>t</sub> = connection for thermometer G ½

	E-Motor 50 Hz			e <sub>1</sub>	l	l <sub>1</sub>	l <sub>2</sub>	m	o <sub>1</sub> *	o <sub>2</sub> *	q	weight abt. kg at motor			
	size-	IP 55	EEx e II T3									IP 55	EEx e II T3		
LPH 75320	225 M	30	-	950	1750	650	110	70	807	2048	641	938	-		
	225 M	-	27									-	1060		
LPH 75330	250 M	37	-	1300	2100	900	210	170	930	2321	791	1260	-		
	280 S	-	40									-	1420		
LPH 75340	280 S	45	-			110	70	70	1005	2496	1044	2535	891	1460	-
	280 S	-	40											-	1490
	280 M	-	46	870	80									40	1095

flange connections to DIN 2501 PN 10				
DN	50	80	100	200
k	125	160	180	295
D	165	200	220	340
number x d <sub>2</sub>	4 x 18	8 x 18	8 x 18	8 x 22

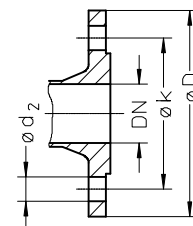

\* Dimensions depend on the motor make

Arrangement drawing LPH 75320, LPH 75330, LPH 75340 with upright liquid separator

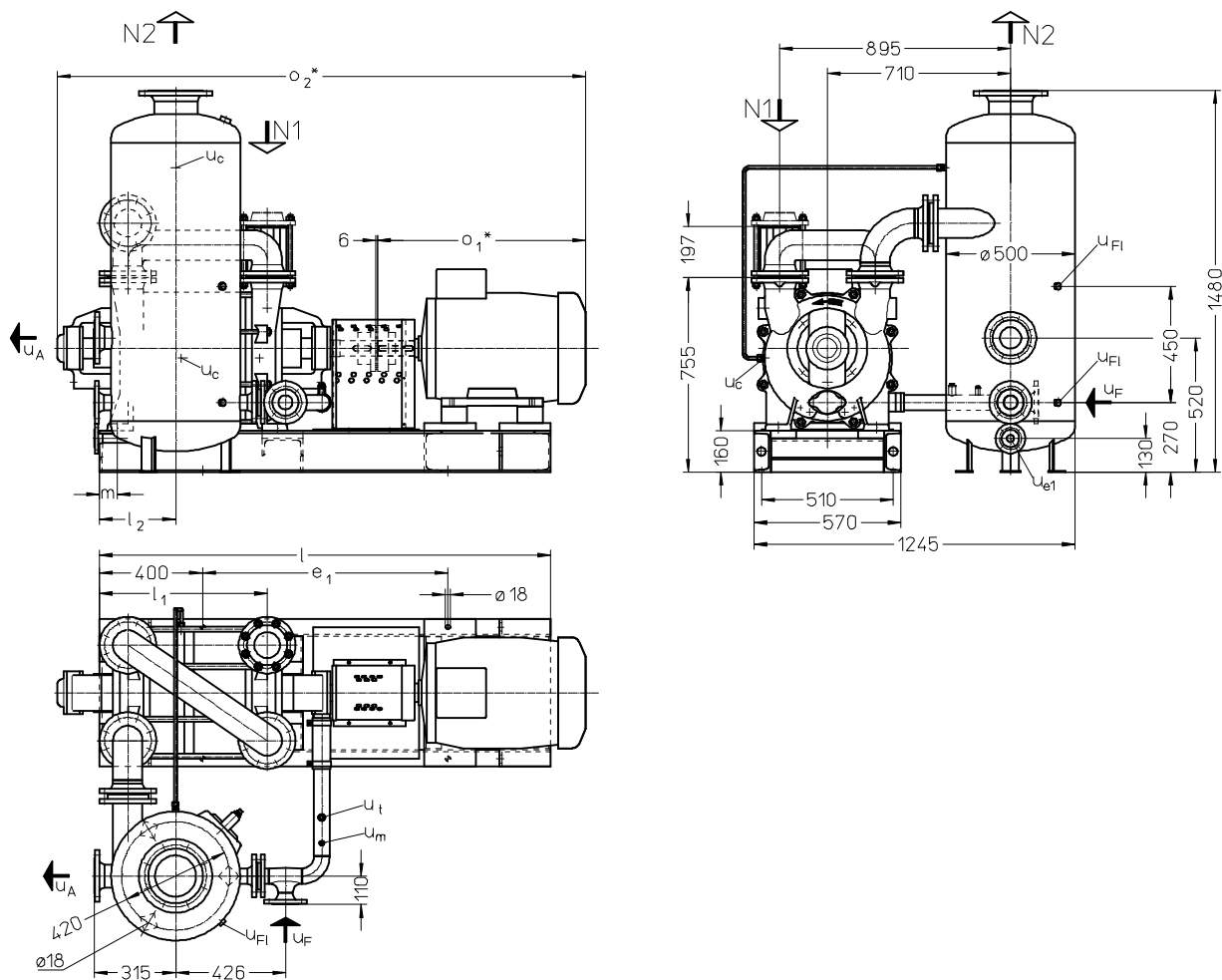

- N 1 = gas-inlet DN 100
- N 2 = gas-outlet DN 150
- u<sub>A</sub> = connection for liquid drain DN 80
- u<sub>c</sub> = connection for protection against cavitation G <sup>3</sup>/<sub>8</sub>
- u<sub>e1</sub> = drain connection DN 25
- u<sub>F</sub> = connection for fresh liquid DN 50
- u<sub>FI</sub> = connection for liquid level indicator G <sup>1</sup>/<sub>2</sub>
- u<sub>m</sub> = connection for pressure gauge G <sup>1</sup>/<sub>4</sub>
- u<sub>t</sub> = connection for thermometer G <sup>1</sup>/<sub>2</sub>

	E-Motor 50 Hz			e <sub>1</sub>	l	l <sub>1</sub>	l <sub>2</sub>	m	o <sub>1</sub> *	o <sub>2</sub> *	weight abt. kg at motor			
	size	IP 55	kW EEx e II T3								IP 55	EEx e II T3		
LPH 75320	225 M	30	-	950	1750	650	295	70	807	2048	965	-		
	225 M	-	27								-	1090		
LPH 75330	250 M	37	-	1300	2100	900	395	170	930	2321	1290	-		
	280 S	-	40								-	1450		
LPH 75340	280 S	45	-			295	70	1005	2496	1490	1044	2535	-	-
	280 S	-	40										-	1520
	280 M	-	46	-	1575									

flange connections to DIN 2501 PN 10					
DN	25	40	50	100	150
k	85	110	125	180	240
D	115	150	165	220	285
Anzahl x d <sub>2</sub>	4 x 14	4 x 18	4 x 18	8 x 18	8 x 22

\* Dimensions depend on the motor make

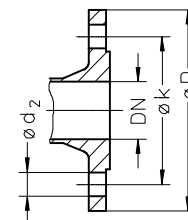

**Fresh water requirements** in [m<sup>3</sup>/h] dependent on suction pressure, speed, mode of operation and difference in temperature

suction pressure [mbar]		33				120				200				400							
pump type	speed rpm	KB				FB	KB				FB	KB				FB					
		difference in temperature [°C]					difference in temperature [°C]					difference in temperature [°C]									
		20	10	5	2		20	10	5	2		20	10	5	2		20	10	5	2	
LPH 75320	880	0,7	1,3	2,2	3,8	7	0,8	1,3	2,2	3,5	6	0,8	1,3	2,1	3,2	5	0,7	1,2	1,7	2,3	3
	975	0,8	1,5	2,4	4,0		0,8	1,5	2,4	3,7		0,9	1,5	2,3	3,4		0,8	1,3	1,8	2,3	
	1175	1,2	2,0	3,1	4,7		1,2	2,0	3,0	4,3		1,2	1,9	2,8	3,8		1,0	1,5	2,0	2,5	
LPH 75330	880	1,0	1,7	2,7	4,3	7	1,0	1,7	2,6	3,9	6	1,0	1,6	2,5	3,5	5	0,8	1,3	1,8	2,4	3
	975	1,1	1,8	2,9	4,5		1,1	1,9	2,8	4,2		1,1	1,8	2,7	3,7		1,0	1,5	2,0	2,5	
	1175	1,5	2,4	3,6	5,1		1,4	2,3	3,3	4,6		1,4	2,2	3,1	4,0		1,2	1,7	2,2	2,6	
LPH 75340	880	1,0	1,8	2,9	4,4	7	1,1	1,8	2,8	4,1	6	1,1	1,8	2,6	3,7	5	1,0	1,5	2,0	2,5	3
	975	1,2	2,0	3,1	4,7		1,2	2,0	3,0	4,3		1,2	2,0	2,8	3,8		1,1	1,6	2,1	2,5	
	1175	1,6	2,6	3,8	5,3		1,7	2,6	3,6	4,7		1,6	2,5	3,3	4,2		1,3	1,8	2,3	2,7	

FB = fresh liquid requirements

KB = combined liquid service water 20°C, 10 °C, 5 °C, 2 °C warmer than the fresh water.

### Data regarding the pump size - order hints

series + size	bearing + direction of rotation	shaft sealing	material design	casing seal
	<ul style="list-style-type: none"> <li>• B two grease lubricated antifriction bearing</li> <li>• N one shaft end clockwise</li> </ul>	041 double gland packing 135 mechanical seal with built-in flashing O-rings Perbunan	02 main parts GG without non-ferrous metal 42 main parts Cr Ni Mo-cast steel	0 liquid seal
LPH 75320 75330 75340	BN	041, 135	02, 42	0

### Design - Motor selection table

	designation	electric motor 50 Hz					
		motor protection IP 55			motor protection EEx e II T3		
pump with free shaft end	01	kW	size	designation	kW	size	designation
pump with couplings, rough-drilled at motor side	04						
as above, but with motor, e.g. 37 kW three phase motor (50 Hz, 400 VΔ) at 975 rpm	e.g. BC	30	225 M	AC	27	225 M	AL
		37	250 M	BC	40	280 S	CL
		45	280 S	CC	46	280 M	DL

#### Example for ordering:

The pump size LPH 75330 BN 041 42 0 with 37 kW three phase motor (50 Hz, 400 VΔ) 975 rpm IP55 has the complete order number:

**LPH 75330 BN 041 42 0 BC**

Motor: If motors with the other voltage and frequency are required a special information should be given.

On delivery the point (•) in the fourth place of the type code is replaced by a letter in the factory.

## Accessories

Recommended accessories			LPH 75320	LPH 75330	LPH 75340
<b>Overhead liquid separator</b>				XBa 10040 70 kg	
material design	130 / galvanized 172 / 1.4571	type weight SIHI part no.		35000443 35000444	
service liquid line					
material design	072 / St 37-0 172 / 1.4571	SIHI part no.	35003195 35003196	35003197 35003198	35003199 35003200
cavitation protection line					
material design	072 / St 37-0 172 / 1.4571	SIHI part no.		on request	
<b>Upright liquid separator</b>				XBp 2311 96 kg	
material design	130 / galvanized 172 / 1.4571	type weight SIHI part no.		35000568 35000569	
service liquid line					
material design	072 / St 37-0 172 / 1.4571	SIHI part no.	35003180 35003181	35003182 20027246	35003183 35003184
cavitation protection line					
material design	072 / St 37-0 172 / 1.4571	SIHI part no.		on request	
discharge line (bend)					
material design	072 / St 37-0 172 / 1.4571	SIHI part no.		35003231 35003232	
<b>Sterling SIHI ball type non-return valve</b>				XCk 100 / 16 resp. 17,5 kg	
material design	767 / GG-25 784 / 1.4408	type/weight SIHI part no.		43016898 43029322	
<b>Motor</b> in case of standard design					
IP 55		size power weight	225 M 30 kW 225 kg	250 M 37 kW 410 kg	280 S 45 kW 540 kg
EEx e II T3		size power weight	225 M 27 kW 350 kg	280 S 40 kW 570 kg	280 M 46 kW 625 kg
<b>Couplings</b>				A 180 / 14 kg	
for motor IP 55				43035527	
pump side		type/weight SIHI part no.	43021496	43034392	43021495
motor side					
for motor EEx e II T3				ADS 194 / 17,5 kg	
pump side		type/weight SIHI part no.	43028518	43035601	43038708
motor side					ADS 218 / 24 kg 43040602
<b>Contact safety device</b>				43042330	
material design	076 / steel 345 / 2.0321	SIHI part no.		43042331	
<b>Base frame</b>				160 kg	
material design	003 / GG-25	type/weight SIHI part no.	142 kg 35002930	35002954	

Any changes in the interest of the technical development are reserved.

### Sterling SIHI GmbH

Lindenstraße 170, D-25524 Itzehoe, Germany, Telephone +49 (0) 48 21 / 7 71 - 01, Fax +49 (0) 48 21 / 7 71 - 274