

Liquid ring vacuum pumps

two stage



LPH 85340, LPH 85353

Pressure range: 33 to 1013 mbar
Suction volume flow: 1100 to 3100 m³/h

CONSTRUCTION TYPE

Sterling SIHI liquid ring vacuum pumps are displacement pumps of uncomplicated and robust construction with the following particular features:

- handling of nearly all gases and vapours
- non polluting due to a nearly isothermal compression
- oil-free, as no lubrication in the working chamber
- small quantities of entrained liquid can be handled
- easy maintenance and reliable operation
- low noise and nearly free from vibration
- wide choice of material, therefore applicable nearly anywhere
- protection against cavitation as standard
- incorporated dirt drain
- no metallic contact of the rotating parts

The Sterling SIHI liquid ring vacuum pumps LPH 95354 and LPH 95367 are two stage pumps.

APPLICATION

Handling and exhausting of dry and humid gases; entrained liquid can be handled during normal duty. The pumps are applied in all fields where a pressure of 33...900 mbar must be created by robust vacuum pumps.

Fields of application are for example:

- chemistry and pharmacy for distilling and degassing,
- electric industry for impregnation and drying
- plastics industry for degassing etc.



NOTE

During operation the pump must continuously be supplied with service liquid, normally water, in order to eliminate the heat resulting from the gas compression and to replenish the liquid ring, because part of the liquid is leaving the pump together with the gas. This liquid can be separated from the gas in a liquid separator (see catalogue part accessories).

It is possible to reuse the service liquid. The pumps are with a device by which the contaminated service liquid can be drained during operating (dirt drain), if necessary.

The direction of the rotation is clockwise, when looking from the drive on the pump.

GENERAL TECHNICAL DATA

pump type	unit	LPH 85340			LPH 85353		
		700	735 ¹⁾	880	700	735 ¹⁾	880
Speed	rpm	700	735 ¹⁾	880	700	735 ¹⁾	880
¹⁾ normal speed							
Max. compression over pressure	bar				1,5		
Max. admissible difference	bar	1,5	1,5	1,2 ²⁾	1,5	1,5	1,2 ²⁾
²⁾ in case of belt drive				1,5			1,5
Hydraulic test (over pressure)	bar				3		
Moment of inertial of the rotating pump parts and the water filling	kg · m ²		8,5			10	
Sound pressure level at a suction of 80 mbar	dB (A)	80	80	82	80	80	82
Min. pulley diameter permissible in case of V-belt drive	mm		315			450	
Max. gas temperature	°C				160		
dry	°C				80		
saturated							
service liquid							
max. admissible temperature	°C				60		
max. viscosity	mm ² /s				90		
max. density	kg/m ³				1200		
volume up to shaft	liter		75			91	
max. flow resistance of the heat exchanger	bar				0,2		

The combination of several limiting values is not admissible.

Material design

Item	COMPONENTS	MATERIAL DESIGN
		02
0001, 0002	Casing	0.6025
0010, 0011, 0012, 0013	Guide disk	0.6025
0030, 0031	Vane wheel impeller	1.0570
0035, 0036	Central body	1.0038
0200	Shaft	1.0503
0270, 0271	Shaft sleeve	1.4027.05
0400	Gland packing	GORE
0500, 0600	Mechanical seal	Cr-steel / carbon / Viton

Sectional drawing LPH 85340, LPH 85353

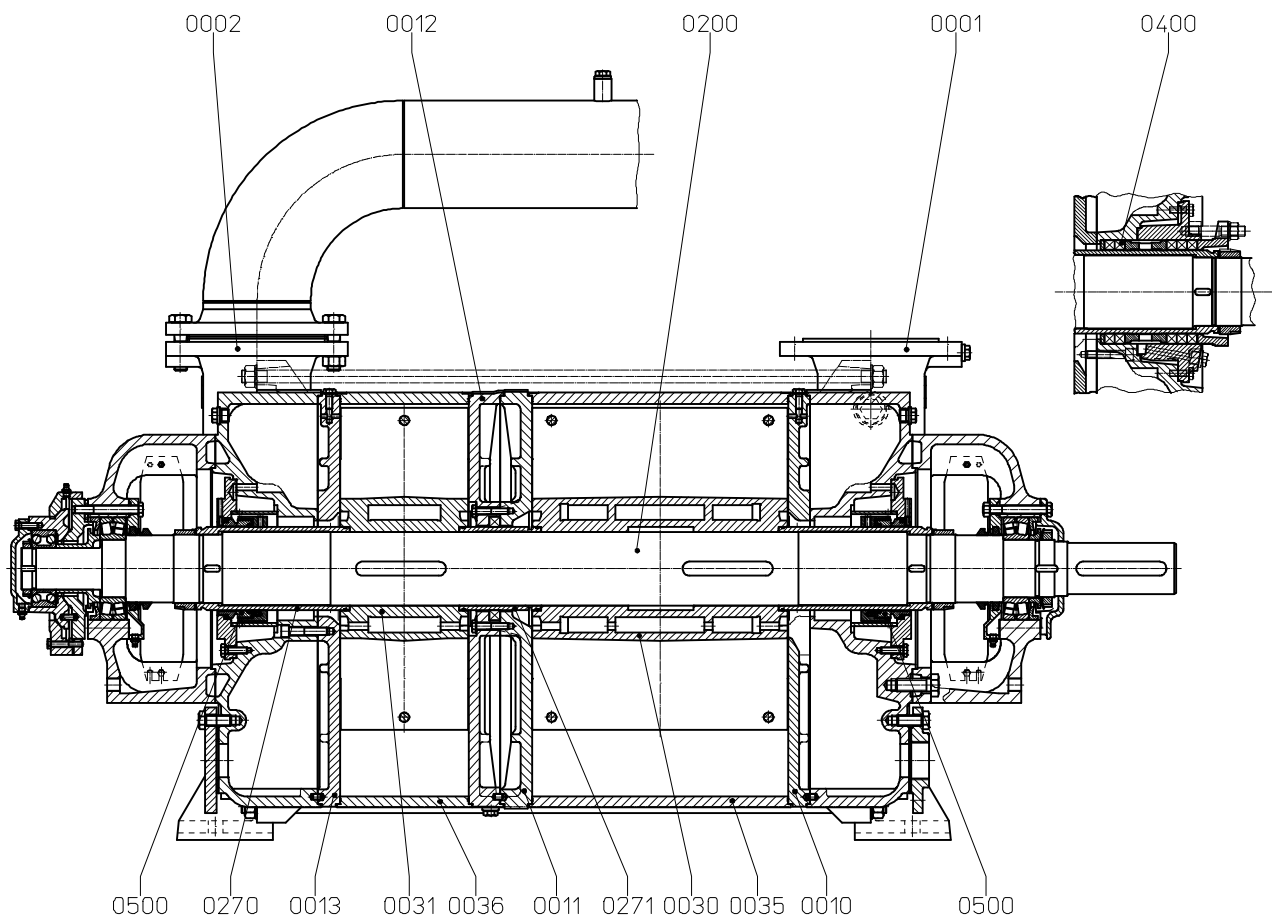

Suction volume flow and power absorption LPH 85340

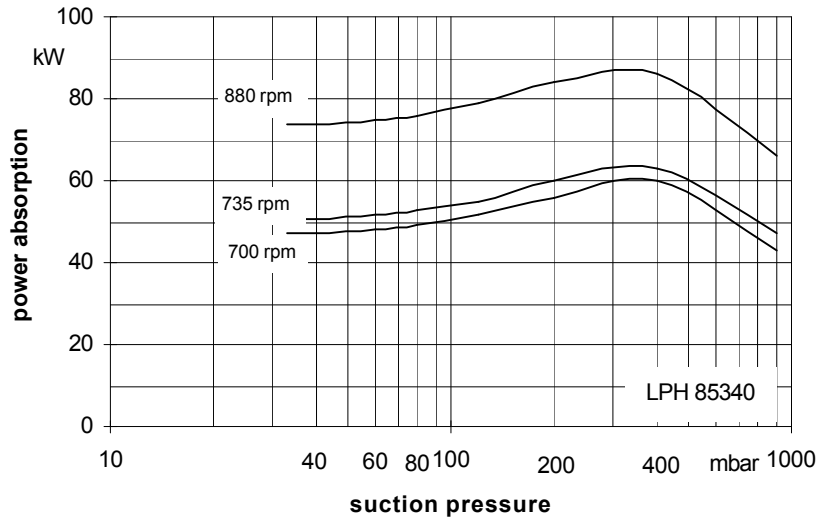
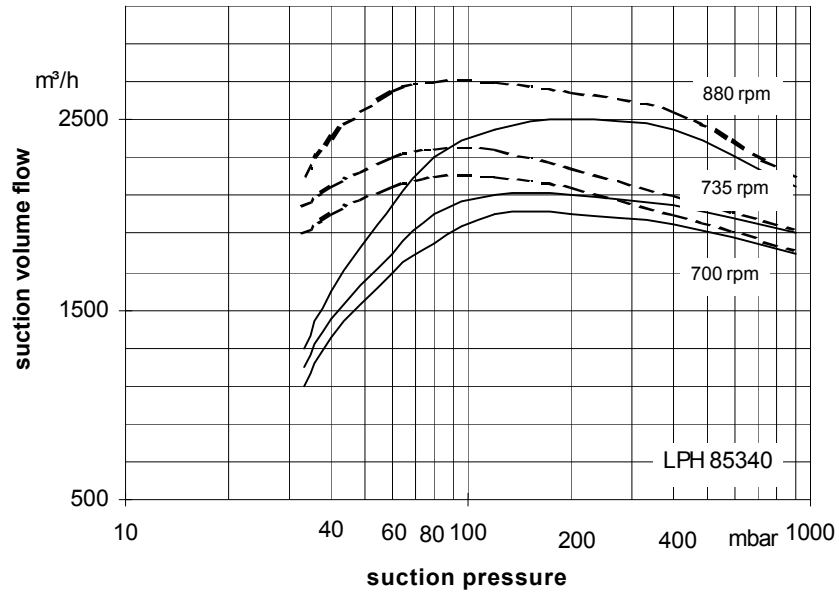

The operating data are applicable under the following conditions:

- pumping medium:
 - dry air: 20°C _____
 - water vapour saturated air: 20°C - - - - -
- service liquid:
 - water: 15°C _____

Compression pressure 1013 mbar (atmospheric pressure)
 The suction volume flow is applied to the suction pressure
 Tolerance of the operating data 10%
 Max. fresh water need with lowest suction pressure

Suction volume flow and power absorption LPH 85353

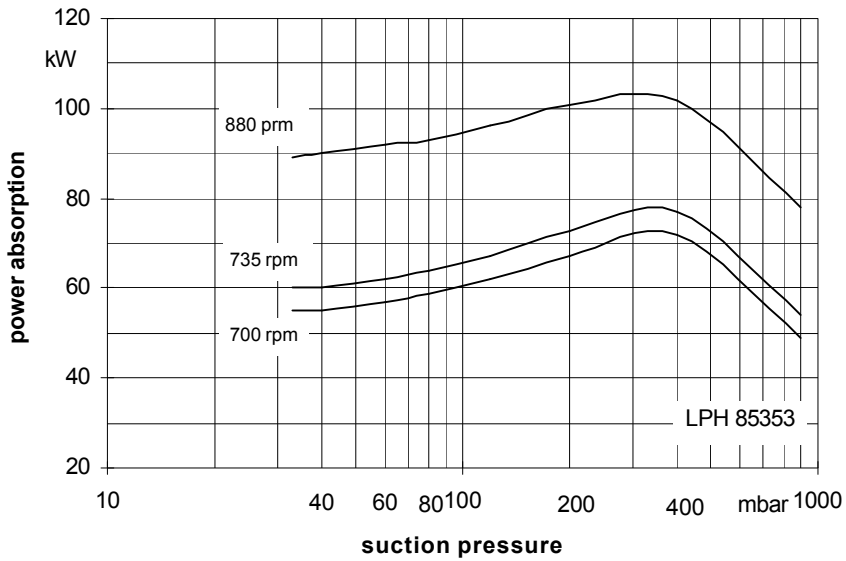
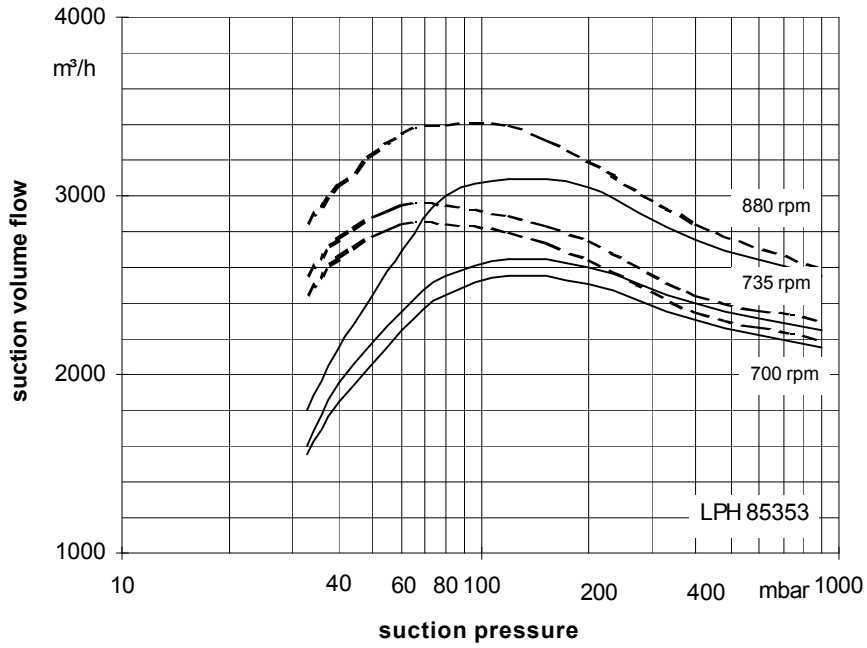

The operating data are applicable under the following conditions:

- pumping medium:
 - dry air: 20°C _____
 - water vapour saturated air: 20°C - - - - -
- service liquid:
 - water: 15°C

Compression pressure 1013 mbar (atmospheric pressure)
 The suction volume flow is applied to the suction pressure
 Tolerance of the operating data 10%
 Max. fresh water need with lowest suction pressure

Dimension table LPH 85340, LPH 85353

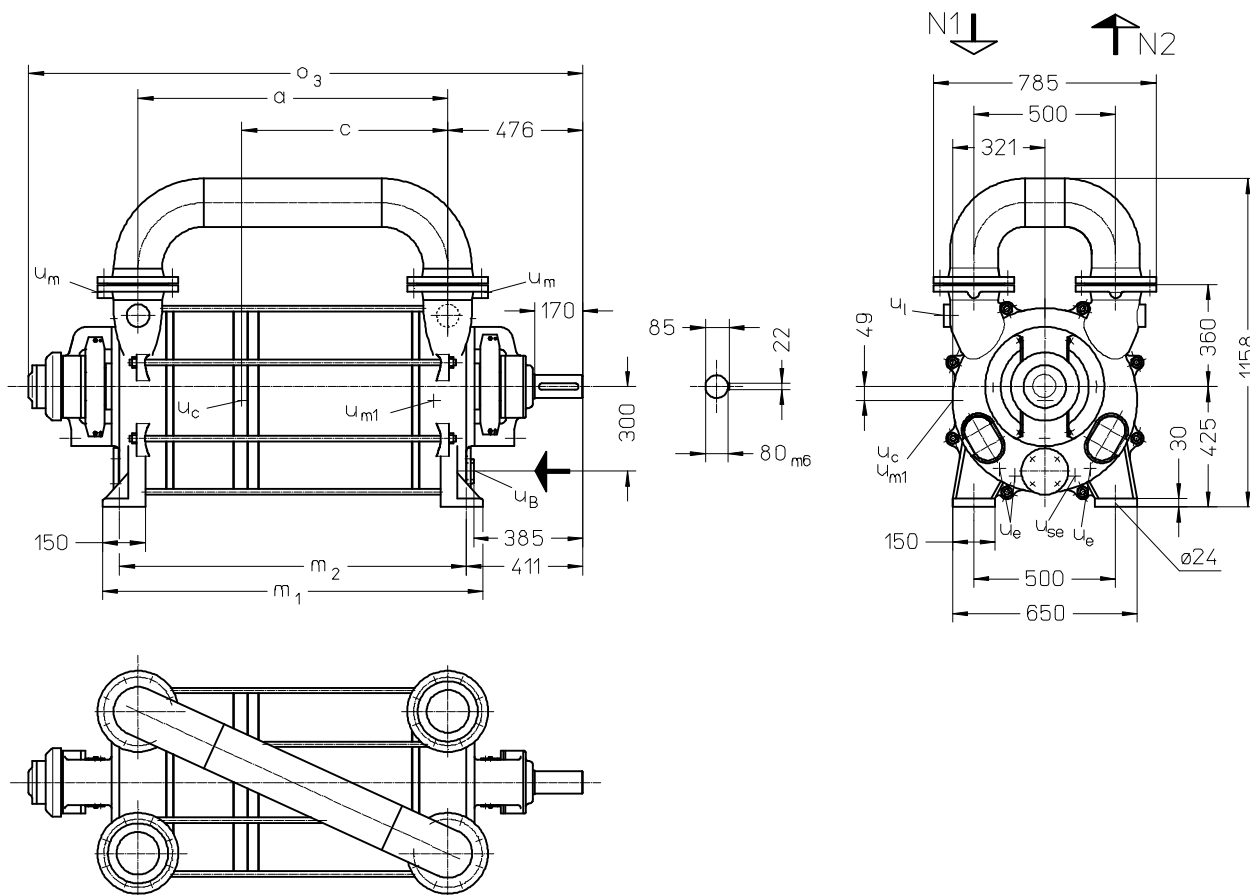

- N 1 = gas inlet DN 150
- N 2 = gas outlet DN 150
- u_B = connection for service liquid G 2
- u_c = connection for protection against cavitation G ½
- u_e = drained connection G½
- u_l = connection for vent cock G 1 ½
- u_m = connection for pressure gauge G½
- u_{m1} = connection for drain valve G ½
- u_{se} = connection for dirt drain G ½

	a	c	m ₁	m ₂	o ₃	weight abt. kg for material design	
						02	42
LPH 85340 BN	961	596	1211	1091	1823	1180	1260
LPH 85353 BN	1091	726	1341	1221	1953	1285	1375

flange connections to DIN 2501 PN 10	
DN	150
k	240
D	285
number x d ₂	8 x 23

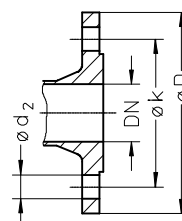

Arrangement drawing LPH 85340, LPH 85353 with upright liquid separator

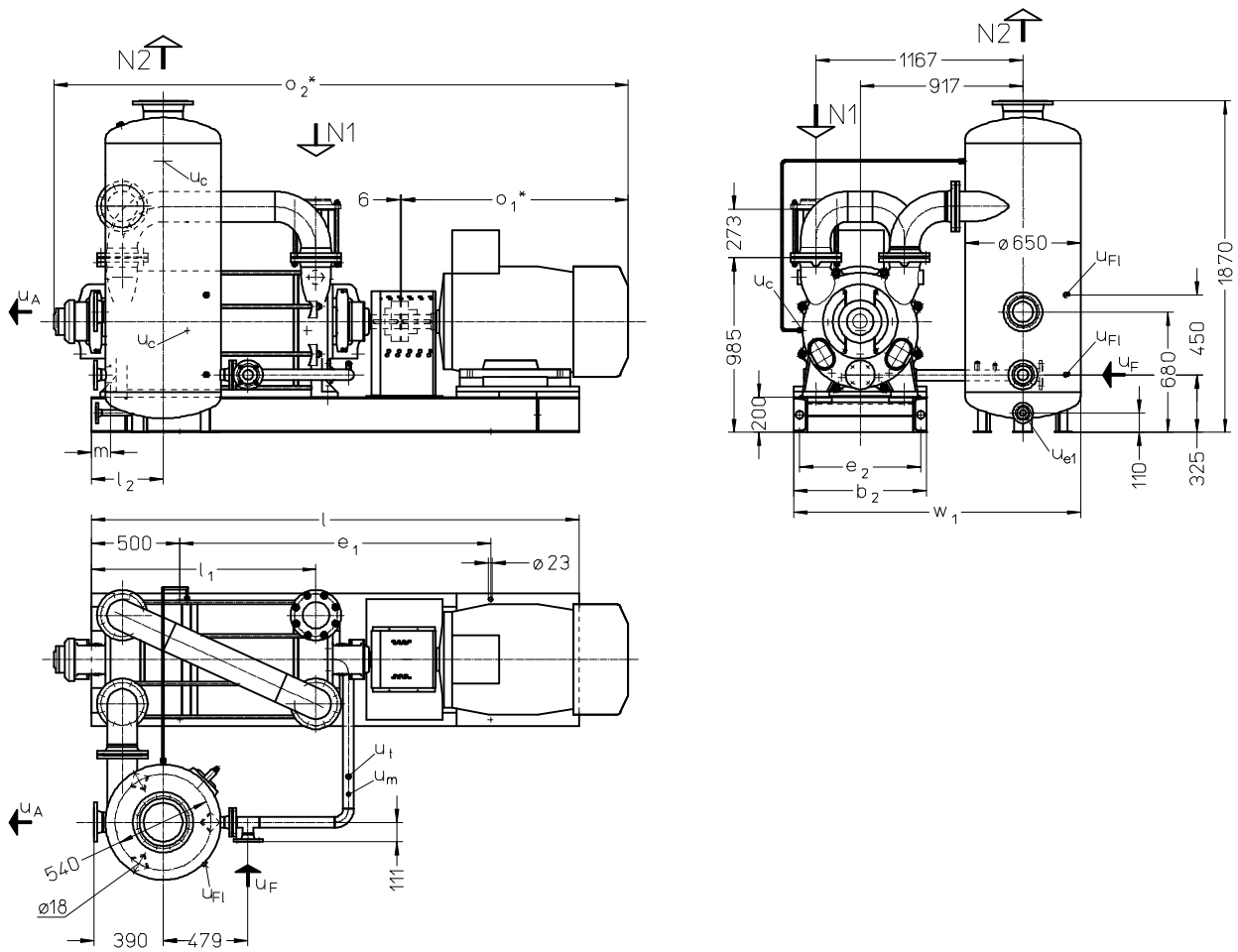

- N 1 = gas inlet DN 150
- N 2 = gas outlet DN 200
- u_A = connection for liquid drain DN 100
- u_c = connection for protection against cavitation G 3/8
- u_{e1} = drained connection DN 25
- u_F = connection for fresh liquid DN 50
- u_{F1} = connection for liquid level indicator G 1/2
- u_m = connection for pressure gauge G 1/4
- u_t = connection for thermometer G 1/2

	E-Motor 50 Hz				b ₂	e ₁	e ₂	l	l ₁	l ₂	m	o ₁ *	o ₂ *	w ₁	weight abt. kg at Motor IP 55
	size	IP 55	kW EEx e II T3												
LPH 85340	315M	75			730	1550	660	2550	1116	385	90	1140	2970	1607	2412
	315M		68									1251	3080		-
LPH 85353	315L	90			750	1750	680	2750	1266	405	110	1280	3240	1617	2602
	315L		80									1371	3330		-
	355M		95									1440	3400		-

flange connections to DIN 2501 PN 10					
DN	25	50	100	150	200
k	85	125	180	240	295
D	115	165	220	285	340
number x d ₂	4 x 14	4 x 18	8 x 18	8 x 22	8 x 22

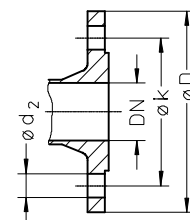

* dimensions depend on the motor make

Fresh water requirements in [m³/h] dependent on suction pressure, speed, mode of operation and difference in temperature

suction pressure [mbar]		33				120				200				400							
pump type	speed [rpm]	KB				FB	KB				FB	KB				FB					
		difference in temperature[°C]					difference in temperature[°C]					difference in temperature[°C]									
		10	5	2			20	10	5	2		20	10	5	2		20	10	5	2	
LPH 85340	700		3,0	4,7	7,1	11	1,8	3,1	4,7	6,9	10	1,9	3,1	4,5	6,3	8,5	1,7	2,5	3,4	4,2	5
	735		3,1	4,9	7,3		1,9	3,2	4,9	7,0		2,0	3,2	4,7	6,4		1,8	2,6	3,4	4,2	
	880		4,0	5,9	8,2		2,5	4,0	5,8	7,7		2,5	3,9	5,3	6,9		2,1	3,0	3,7	4,4	
LPH 85353	700		3,5	5,6	8,8	14	2,2	3,8	5,9	8,7	13	2,3	3,8	5,6	8,0	11	2,1	3,3	4,5	5,7	7
	735		3,8	5,9	9,1		2,4	4,0	6,1	9,0		2,4	4,0	5,9	8,1		2,2	3,4	4,6	5,8	
	880		4,9	7,3	10,2		3,1	5,0	7,3	9,9		3,1	4,9	6,7	8,8		2,7	3,9	5,0	6,0	

FB = fresh liquid service

KB = combined liquid service water 20°C, 10 °C, 5 °C, 2 °C warmer than the fresh water.

Data regarding the pump size - order hints

series + size	bearing + direction of rotation	shaft sealing	material design	casing seal
	<ul style="list-style-type: none"> B• two grease lubricated antifriction bearing •N one shaft end clockwise rotating 	041 double gland packing BFG mechanical seal with built-in flushing O-rings Viton	02 main parts GG without non-ferrous metal	0 liquid seal
LPH 85340 85353	BN	041, BFG	02	0

Design - Motor selection table

	construction type	electric motor 50 Hz					
		motor protection IP 55			motor protection EEx e II T3		
pump with free shaft end	01	kW	size	designation	kW	size	designation
pump with coupling, pre-drilled at motor side	04						
as above, but with motor, e.g. 75kW three-phase motor (50 Hz, 400 VΔ) at 735 rpm	e.g. FD	75	315M	FD	68	315M	FM
		80	315M		80	315M	HM
		90	315L	GD	95	355M	KM

Example for ordering:

The pump size LPH 85340 BN 041 02 0 with 75 kW three phase motor (50 Hz, 400 VΔ) 735 rpm IP55 is the complete order number:

LPH- 85340 BN 041 02 0 FD

Motor: If motors with the other voltage and frequency are required a special information should be given.

On delivery the point (•) in the fourth place of the type code is replaced by a letter in the factory.

Accessories

Recommended accessories			LPH 85340	LPH 85353
Upright liquid separator		type	XBp 5013	
material design 130 / galvanized		weight	148 kg	
172 / 1.4571		SIHI part No.	35000585	
service liquid line			35000586	
material design 072 / St 37-0		SIHI part No.	35003189	35007072
172 / 1.4571			35003190	35003191
discharge line (bend)				
material design 072 / St 37-0		SIHI part No.	35003237	
172 / 1.4571			35003238	
Sterling SIHI-ball type non-return valve		type / weight	XCk 150 / 28 resp. 35 kg	
material design 767 / GG25		SIHI part No.	43016900	
784 / 1.4408			43030924	
Base frame				
material design 081 / steel		type / weight	417 kg	423 kg
		SIHI part No.	35012206	35012207

Any changes in the interest of the technical development are reserved.

Sterling SIHI GmbH

Lindenstraße 170, D-25524 Itzehoe, Germany, Telephone +49 (0) 48 21 / 7 71 - 01, Fax +49 (0) 48 21 / 7 71 - 274