

Liquid ring vacuum pumps

two stage



LPH 95354, LPH 95367

Pressure range: 33 to 1013 mbar
Suction volume flow: 2000 to 4200 m³/h

CONSTRUCTION TYPE

Sterling SIHI liquid ring vacuum pumps are displacement pumps of uncomplicated and robust construction with the following particular features:

- handling of nearly all gases and vapours
- non polluting due to a nearly isothermal compression
- oil-free, as no lubrication in the working chamber
- small quantities of entrained liquid can be handled
- easy maintenance and reliable operation
- low noise and nearly free from vibration
- wide choice of material, therefore applicable nearly anywhere
- protection against cavitation as standard
- incorporated dirt drain
- no metallic contact of the rotating parts

The Sterling SIHI liquid ring vacuum pumps LPH 95354 and LPH 95367 are two stage pumps.



NOTE

During operation the pump must continuously be supplied with service liquid, normally water, in order to eliminate the heat resulting from the gas compression and to replenish the liquid ring, because part of the liquid is leaving the pump together with the gas. This liquid can be separated from the gas in a liquid separator (see catalogue part accessories).

It is possible to reuse the service liquid. The pumps are with a device by which the contaminated service liquid can be drained during operating (dirt drain), if necessary.

The direction of the rotation is clockwise, when looking from the drive on the pump.

APPLICATION

Handling and exhausting of dry and humid gases; entrained liquid can be handled during normal duty. The pumps are applied in all fields where a pressure of 33...900 mbar must be created by robust vacuum pumps.

Fields of application are for example:

- chemistry and pharmacy for distilling and degassing,
- electric industry for impregnation and drying
- plastics industry for degassing etc.

GENERAL TECHNICAL DATA

Pump type	unit	LPH 95354	LPH 95367
Speed			
¹⁾ normal speed	rpm	465	585 ¹⁾ 700
Max. compression over pressure	bar		1,5
Max. admissible difference	bar	1,5	1,5 1,2 ²⁾
²⁾ in case of belt drive			1,5
Hydraulic test (over pressure)	bar		3
Moment of inertial of the rotating pump parts and of the water filling	kg · m ²	28	32
Sound pressure level at a suction of 80 mbar	dB (A)	87	88 90
Min. pulley diameter permissible in case of V-belt drive	mm	710	800
Max. gas temperature	°C		160
	dry		80
	saturated		
Service liquid:			
max. admissible temperature	°C		60
max. viscosity	mm ² /s		90
max. density	kg/m ³		1200
volume up to shaft	liter	228	250
Max. flow resistance of the heat exchanger	bar		0,2

The combination of several limiting values is not admissible.

Material design

Item	COMPONENTS	MATERIAL DESIGN	
			02
0001, 0002	Casing		0.6025
0010, 0011, 0012, 0013	Guide disk		0.6025
0030, 0031	Vane wheel impeller		1.0570
0035, 0036	Central body		1.0038
0200	Shaft		1.0503
0270, 0271	Shaft sleeve		1.4027.05
0400	Gland packing		GORE

Sectional drawing LPH 95354, LPH 95367

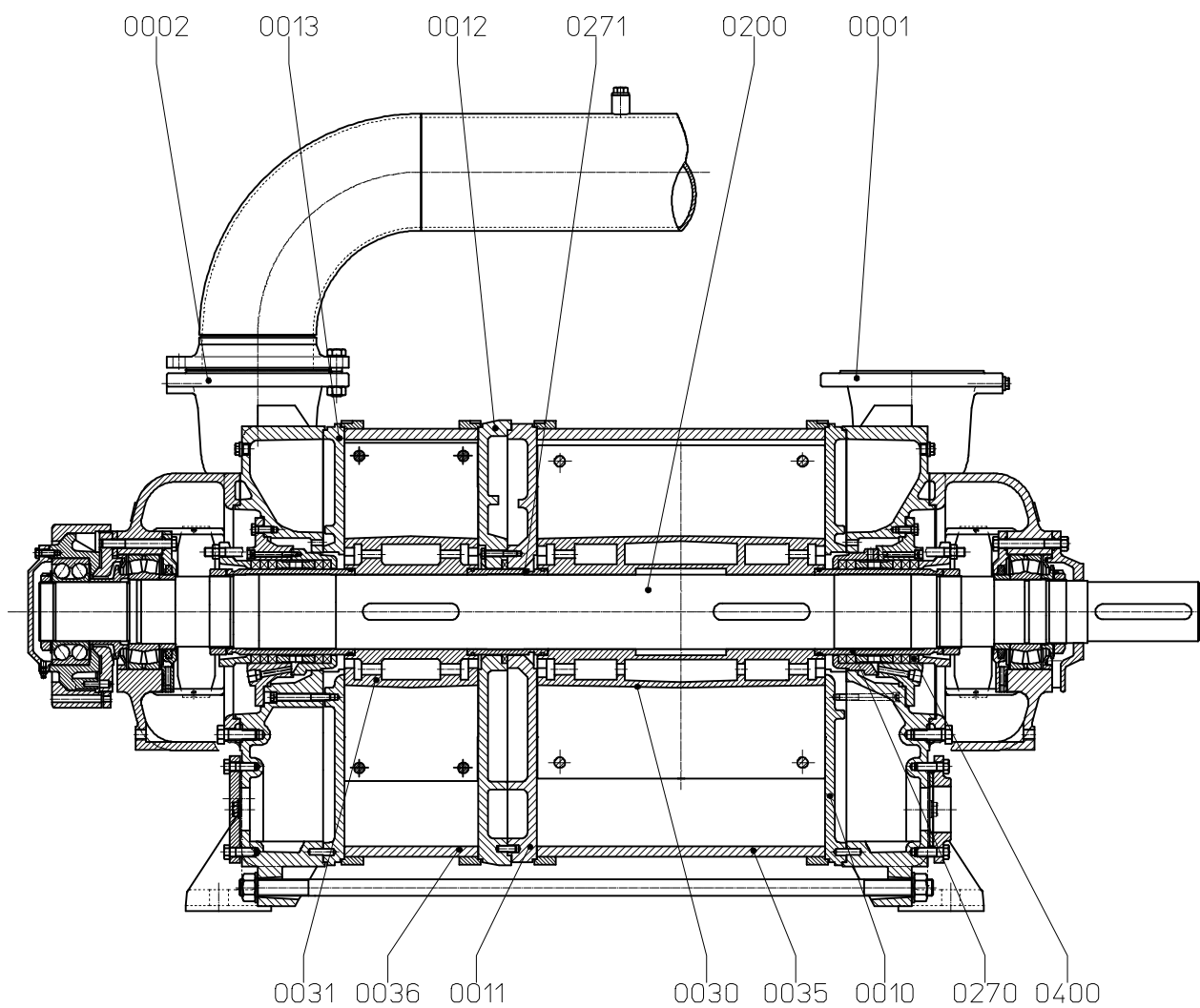

Suction volume flow and power absorption LPH 95354

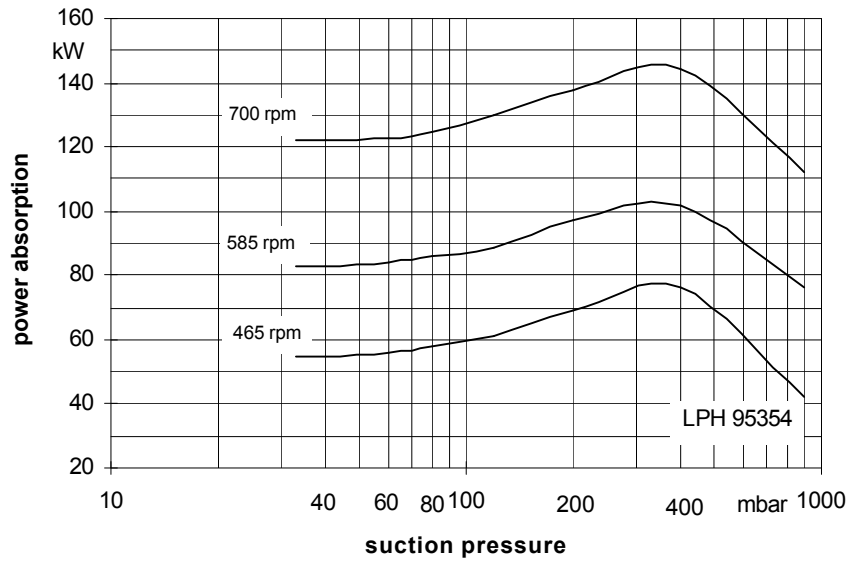
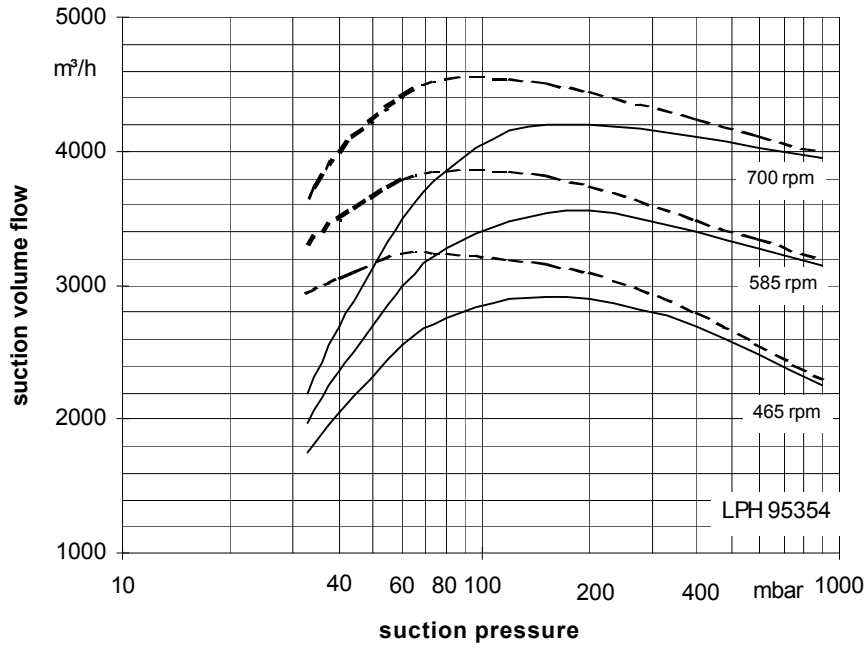

The operating data are applicable under the following conditions:

- pumping medium:
 - dry air: 20°C _____
 - water vapour saturated air: 20°C - - - - -

- service liquid:
 - water: 15°C

Compression pressure 1013 mbar (atmospheric pressure)
 The suction volume flow is applied to the suction pressure
 Tolerance of the operating data 10%
 Max. fresh water need with lowest suction pressure

Suction volume flow and power absorption LPH 95367

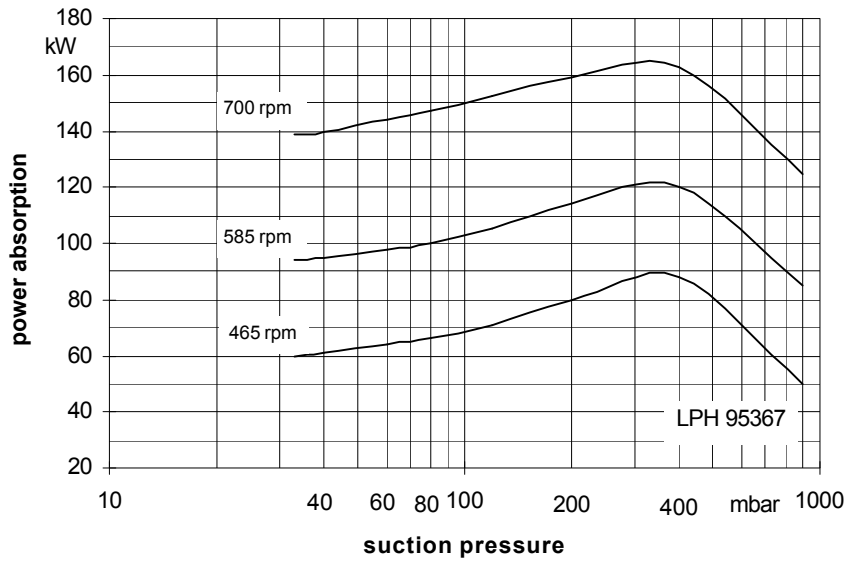
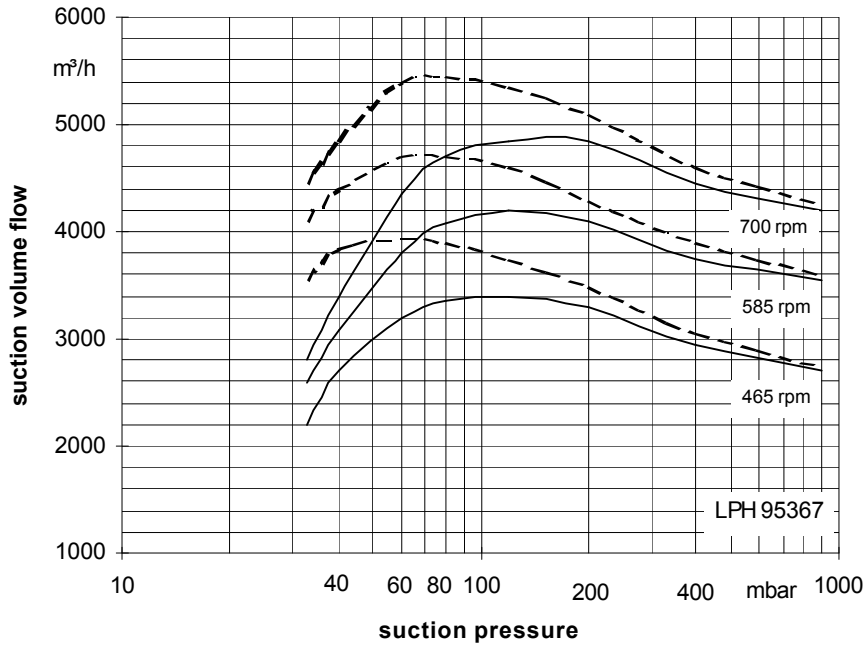

The operating data are applicable under the following conditions:

- pumping medium:
 - dry air: 20°C _____
 - water vapour saturated air: 20°C - - - - -
- service liquid:
 - water: 15°C _____

Compression pressure 1013 mbar (atmospheric pressure)

The suction volume flow is applied to the suction pressure

Tolerance of the operating data 10%

Max. fresh water need with lowest suction pressure

Dimension table LPH 95354, LPH 95367

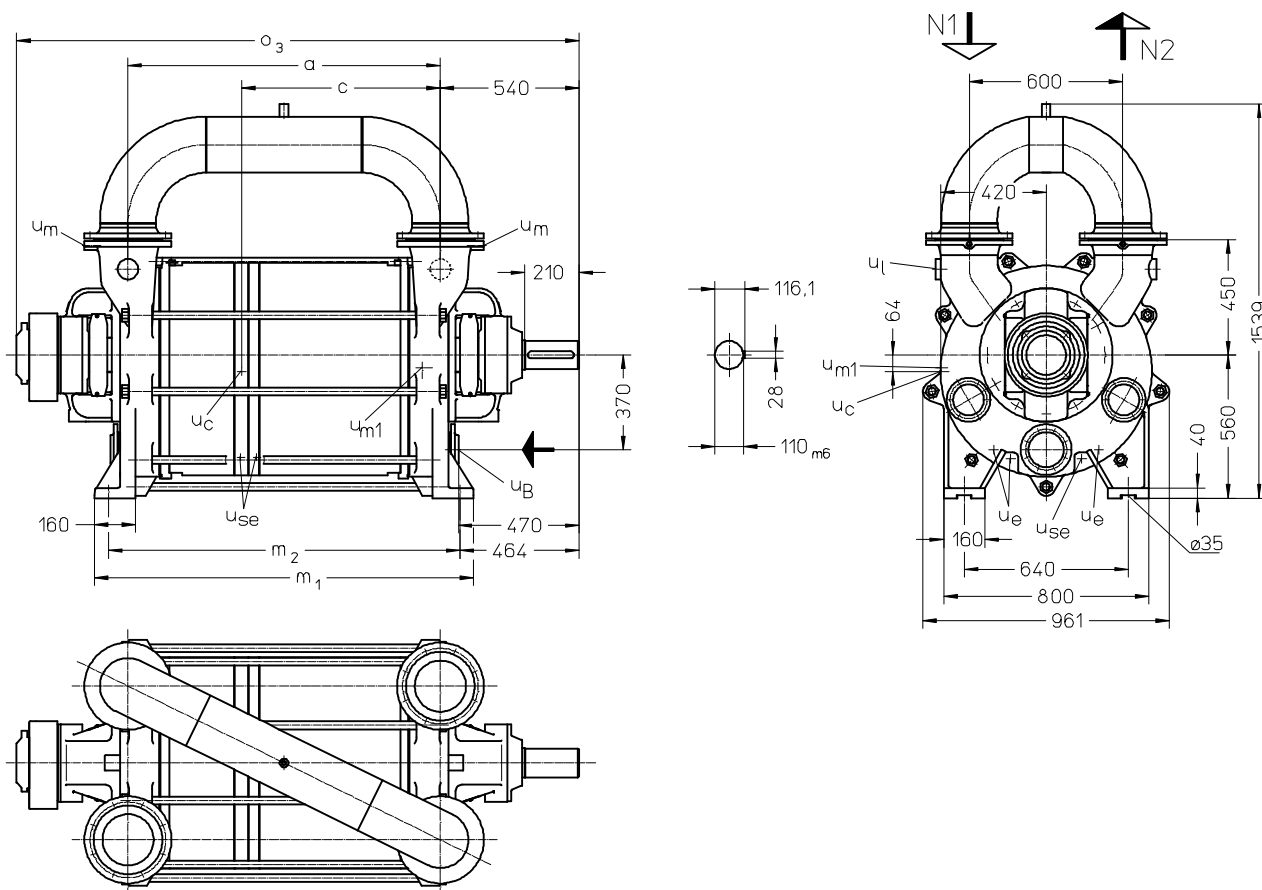

- N 1 = gas-inlet DN 200
- N 2 = gas-outlet DN 200
- u_B = connection for service liquid G 3
- u_c = connection for protection against cavitation G ½
- u_e = drain connection G3/4
- u_l = connection for vent cock G 1 ½
- u_m = connection for pressure gauge G½
- u_{m1} = connection for drain valve G ¾
- u_{se} = connection for dirt drain G ¾

	a	c	m ₁	m ₂	o ₃	weight abt. kg for material design	
						02	42
LPH 95354 BN	1219	776	1479	1371	2194	2300	2500
LPH 95367 BN	1344	901	1604	1496	2319	2500	2700

flange connections to DIN 2501 PN 10	
DN	200
k	295
D	340
number x d ₂	8 x 23

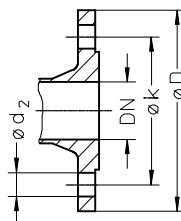

Fresh water requirements in [m³/h] dependent on suction pressure, speed, mode of operation and difference in temperature

suction pressure [mbar]		33				120				200				400							
pump type	speed [rpm]	KB			FB	KB				FB	KB				FB	KB				FB	
		difference in temperature [°C]				difference in temperature [°C]					difference in temperature [°C]					difference in temperature [°C]					
		10	5	2		20	10	5	2		20	10	5	2		20	10	5	2		
LPH 95354	465		3,8	6,3	10,5	19	2,3	4,1	6,6	10,7	18	2,5	4,3	6,8	10,4	16	2,5	4,1	6,0	8,2	11
	585		5,2	8,1	12,4		3,2	5,4	8,3	12,2		3,3	5,5	8,2	11,6		3,1	4,9	6,8	8,8	
	700		6,8	10,0	13,9		4,3	6,9	10,0	13,6		4,3	6,8	9,6	12,6		4,0	5,8	7,6	9,3	
LPH 95367	465		4,1	6,9	11,6	21	2,6	4,6	7,4	11,7	19	2,9	4,9	7,6	11,4	17	2,8	4,5	6,4	8,5	11
	700		5,8	9,1	13,8		3,6	6,1	9,3	13,4		3,8	6,2	9,1	12,6		3,5	5,3	7,2	9,1	
	700		7,6	11,2	15,5		4,9	7,7	11,0	14,7		4,9	7,6	10,5	13,6		4,3	6,2	7,9	9,5	

FB = fresh liquid service

KB = combined liquid service water 20 °C, 10 °C, 5 °C, 2 °C warmer than the fresh water.

Data regarding the pump size - order hints

series + size	bearings + direction of rotation	shaft sealing	material design	casing seal
	<ul style="list-style-type: none"> B• two grease lubricated antifriction bearing •N one shaft end clockwise rotating 	041 double gland packing	02 main parts GG without non-ferrous metal	0 liquid seal
LPH 95354 95367	BN	041	02	0

Upon request (dependent on the operating conditions) this vacuum pump is available as complete unit (e.g. pump, couplings, contact safety device and gear mounted on a base frame).

Design - Motor selection table

	designation	electric motor 50 Hz	
pump with free shaft end	01	motor protection IP 55	
pump with coupling, pre-drilled at motor side	04	kW	size
as above, but with gearing, motor and base frame	order with text in clear	90	280M
		110	315S
		132	315M
		160	315L
		200	315L

Motor: If motors with the other voltage, type of protection and frequency are required a special information should be given.

Accessories

Recommended accessories		LPH 95354			LPH 95367		
Upright liquid separator		XBp 10112					
	type	205 kg					
material design	130 / galvanized	35000593					
	172 / 1.4571	20000612					
service liquid line							
material design	072 / St 37-0	20027252			20027253		
	172 / 1.4571	35003228			20027254		
discharge line (bend)							
material design	072 / St 37-0	20027265					
	172 / 1.4571	35003239					
Motor in case of standard design	size	280M	315M	315L	315S	315L	315L
IP 55	power	90 kW	132 kW	160 kW	110 kW	160 kW	200 kW
	weight abt.	660 kg	910 kg	1060 kg	830 kg	1060 kg	1200 kg

Any changes in the interest of the technical development are reserved.

Sterling SIHI GmbH

Lindenstraße 170, D-25524 Itzehoe, Germany, Telephone +49 (0) 48 21 / 7 71 - 01, Fax +49 (0) 48 21 / 7 71 - 274